

BALMAR®

80-Series Alternators

50, 65, and 100-A Models

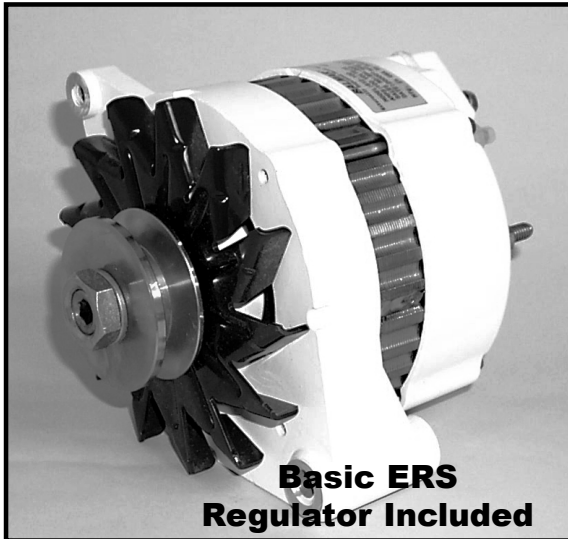

I. INTRODUCTION

Your high-output BALMAR® Marine Alternator is uniquely designed and engineered to provide the finest performance and durability for your vessel. Unlike most automotive-type alternators found standard on the majority of pleasure craft, BALMAR® Marine Alternators are specially designed to provide exceptional output at lower engine r.p.m.'s, so you can enjoy less noise and fumes, increased economy and shorter charge cycles.

II. SAFETY CONSIDERATIONS

Before installing your BALMAR® marine alternator, please take a moment to consider the following guidelines for safe alternator installation. Failure to follow these guidelines could result in injury or damage to your electrical system.

1. Always disconnect your battery's ground cable and turn your battery switch to its OFF position prior to installing your alternator.
2. Remove any loose-fitting clothing or jewelry, which could become entangled in your motor or other machinery.
3. Wear ANSI-approved safety glasses.
4. Do not attempt installation if tired or fatigued.
5. Ensure the engine has cooled sufficiently before initiating installation.
6. Drugs and alcohol do not mix with safe installation procedures. Do not attempt installation while using alcohol or any medication that could impair your judgment or reaction time.
7. Always use the right tool for the job. In addition to causing damage to the alternator or your boat, the use of incorrect or improperly-sized tools can result in personal injury.
8. Take time to read the manual. Equipment damage and possible injuries may result from an incomplete understanding of the installation and operation of the alternator.

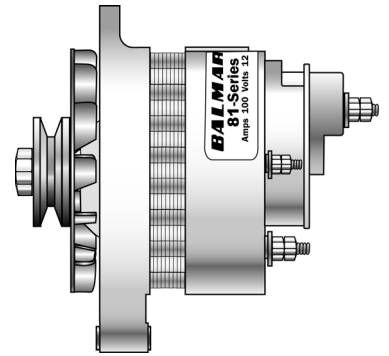

Model 81

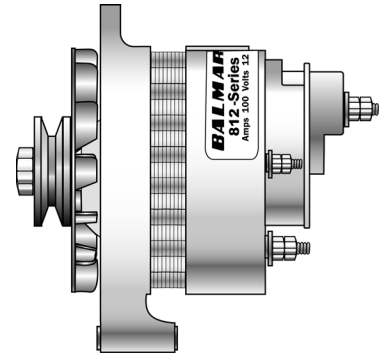

Model 812

TABLE OF CONTENTS

- I. Introduction**
- II. Safety Considerations**
- III. General Information**
- IV. Basic Installation**
- V. Additional Installation Information.**
- VI. Troubleshooting**
- VII. Warranty**
- VIII. Quick Installation Guide**

CAUTION

The following instructions are intended for use by experienced marine electrical installers. If you are not experienced at installing electrical system components, we recommend a qualified marine electrician be used to install this alternator.

III. GENERAL INFORMATION

BALMAR® alternators are available in a wide range of sizes, mounting configurations and amperage outputs to replace or upgrade a wide range of marine alternators. All BALMAR® alternators are “P” type (positive on the field wire), with max field current demand 6 amps and 2.4 ohm rotors in 12/14 volt models.

Amperage Ratings

Alternators are rated in relation to their outputs at our test bench at specific pulley r.p.m. Circuit breakers, fuses and wire gauges should be rated at or above maximum indicated alternator amperage. Actual amperages produced by the alternators after installation may vary due to factors such as battery capacity, battery type, wiring capacity, engine room temperature, and other variables. In most cases, maximum output is determined by your batteries’ absorption rates at their voltage set point.

Voltage Regulation

BALMAR® alternators are engineered for external regulation. A basic, single-stage regulator, set at 14.1 volts, is included with each alternator. (Voltage can vary up to 3% plus or minus. Caution should be used when running for long periods when used with gel type batteries.) While the standard regulator supplied does provide an adequate charge control, we recommend a multi-step regulator for optimized charging. In addition to its ability to provide a smart charging protocol that’s tailored to your battery type, our Max Charge has the ability to monitor and compensate for temperature variation in both the alternator and your batteries (with optional sensors installed). Combined with amp management, soft ramp up and start delay, the Max Charge’s advanced programmability and multi-stage charging help provide the tools to increase charging speed and reduce engine and alternator wear.

Rotation

BALMAR® marine alternators are designed to operate in a clockwise rotation (facing the pulley and fan). This clockwise rotation draws cool air from the back of the alternator across the internal components to maintain proper operating temperatures. Should the alternator be used in a secondary position (mounted in an opposing direction to the engine), or should the alternator be mounted on an “opposite-rotation” engine, the alternator’s pulley must be keyed and/or pinned and the alternator must be equipped with a bi-directional fan. Reverse Rotation Kits are available for most BALMAR® alternators.

Grounding

BALMAR® 80-Series marine alternators are isolated ground. It is essential that the alternator is properly grounded. We strongly recommend you ground your alternator to the negative terminal of your house battery or your vessel’s ground buss with a cable that’s the same size as your output cable. Running your grounding cable directly to the engine’s ground bolt also provides a good source of ground. The regulator’s grounding wires must be attached to the alternator’s negative terminal (see **Figure 4**).

Mechanical and Electrical Noise

As part of normal operation, your BALMAR® marine alternator will make a slight whining noise while under load. This whining noise provides an indicator that the alternator is charging. In addition to a mechanical whine, you may experience a small amount of sticking or drag when the alternator is new. This is caused by the wood separators in the stator. With use, the separators will wear and the sticking will be eliminated.

By nature, electricity producing equipment like alternators may create electrical noise or interference that can be transmitted to radios, radars and other voltage-sensitive electronics. Your BALMAR® alternator has been designed to minimize electrical interference. If interference persists, we recommend adding noise reduction filters to your system. One provider of quality noise reducing filters is Marine Tech, Inc., at (800) 772-0796.

Wire Size

Proper wire size is essential for safe and effective alternator operation. The accompanying Voltage drop chart provides a basic guide that should be used when determining proper wire lengths for charging systems (see **Figure 1**). Wiring used should be marine quality AWG boat cable, rather than SAE automotive wire. Marine-quality wire is normally tinned or treated to protect against the corrosive marine environment. Use only wire that is marked with size and type. In addition to wiring, all connectors used in vessel installations should also be manufactured for marine use.

When determining the proper wire size for your installation, wire length should be measured by the distance required to reach from the positive (+) power source to the electrical device and back to the negative power connection. The chart to the right provides a general guide for wire size. If your specific wiring requirement falls between the values shown, use the larger wire size recommended. Contact the ABYC, BIA or your marine electrician for additional information.

Figure 1
3% Voltage Drop Chart -- Distance reflects "round trip"

Length	10 Ft.	15 Ft.	20 Ft.	25 Ft.	50 Ft.	75 Ft.	100 Ft.
Amps							
25	10	8	8	6	4	2	1
50	8	6	4	4	1	2/0	3/0
75	6	4	2	2	2/0	3/0	4/0
100	4	2	2	1	3/0	4/0	
125	4	2	1	1/0	3/0	4/0	
150	2	1	1/0	2/0	4/0		
175	2	1/0	2/0	3/0			
200	2	1/0	2/0	3/0			
225	1	2/0	3/0	4/0			
250	1	2/0	3/0	4/0			
275	1/0	2/0	4/0				
300	1/0	3/0	4/0				
325	1/0	3/0	4/0				
350	2/0	3/0					
375	2/0	4/0					

Alternator Heat

During operation, your alternator may reach temperatures of 200 degrees as a result of inductive currents. In some instances, particularly during extended periods of heavy load, temperatures can reach 225 degrees (F). Temperatures exceeding that may result in damage. If your system is operating with a Max Charge regulator with optional alternator temperature sensing, the regulator will automatically shut off the alternator when temperatures pass set values, giving the alternator the ability to cool to normal temperatures before returning to operation. While this is an extremely effective device for alternator protection, it should not be used as part of normal alternator maintenance. Continual alternator overheating indicates ventilation or charging system problems and repair is strongly advised.

Use extreme caution when handling the alternator or other engine components during or after use. Should your alternator become so hot that it emits a burning smell, or if there is indication of discoloration at the pulley or pulley shaft, shut off the alternator immediately and (once it becomes safe to inspect the alternator) check the tension of the drive belt. Under-tensioned belts are a leading cause of overheating and alternator damage. For more information, see the Maintenance section of this manual.

Pulleys and Belts

A 2.5" deep V pulley is included with your alternator. This pulley will accommodate from 3/8" to 1/2" single belts or metric equivalents. Belts are not created equally, and in most instances you get what you pay for. Premium quality belts such as Gates' "Tri-Power" or "Green Stripe", Dayco's "Topco", or similar industrial-quality belts will provide a better value over lesser quality belts in both dependability and durability. We strongly recommend you always carry a spare belt as part of your emergency kit. Alternators rated at 75-amps or less should use a minimum belt size of 3/8". Alternators rated at 100-amps should use a minimum belt size of 1/2".

IV. BASIC INSTALLATION

CAUTION: Alternator installation requires substantial amount of mechanical and electrical understanding. If you are not experienced with alternator installations we strongly recommend that you enlist the services of a qualified marine electrician. Keep in mind that alternator performance is only as good as the wiring and battery installation. If you are unsure of the condition of your boat's batteries or wiring, please have them inspected by a qualified electrician before proceeding with the alternator installation.

Alternator Mounting

Due to the many domestic and international configurations of engine/alternator mounts, and factors such as year and location of engine manufacture and marinization, BALMAR® cannot guarantee a drop-in replacement in every circumstance. Choose the BALMAR® model that most closely fits your application. Your installer may have to adapt the basic mounts to fit your needs. The majority of marine engines are equipped with one of two alternator mounting styles (shown in **Figures 2-3**). To determine your alternator requirement, compare your present alternator to those shown below. The single, 1-inch model is typically a replacement for "Motorola®" style alternators. Single, two-inch foot models generally replace Delco® style alternators.

Once you have determined that the new alternator is the correct replacement for your existing model:

1. Turn off batteries, disconnect the ground and detach the wiring from the existing alternator.
2. Loosen the mounting bolt and remove the existing alternator.
3. Once the alternator is disconnected from the engine, compare its mounting points to those on your new BALMAR® alternator. In most applications, the new alternator will replace the old alternator without any modification. In some cases, a simple bracket can be fabricated by a local machine shop. BALMAR® offers a universal mounting arm which may solve some mounting challenges. Others can be obtained through your local auto or marine supply.
4. Attach the mounting foot of the new alternator to its engine mount. Some shimming may be necessary to ensure that the alternator is securely mounted within the engine mount. If your alternator is a dual foot style, use care when tightening the alternator in place that the two mounting ears are not compressed. The rear bushing is designed to slide to tighten the mount.
5. Once in place, inspect to ensure that the alternator pulley is properly aligned with the engine pulley. If your belt configuration includes the pulley for the water pump, make sure that all three pulleys are properly aligned.
6. Your new alternator is shipped with a simple, single-stage regulator with six wires connected to its epoxy potting. (See **Figure 4.**) The wiring is arranged as follows:
 - a. **Brown (Br)** Ignition (source) Wire: Attaches to the auxiliary side of the vessel's ignition switch, or an independent oil pressure switch to turn on regulator. Used when the orange wire is NOT used.
 - b. **Orange (O)** Lamp Wire: This wire turns on the regulator when connected to a warning lamp that is connected to the aux. side of the key switch (optional). Used when the brown wire is NOT used.

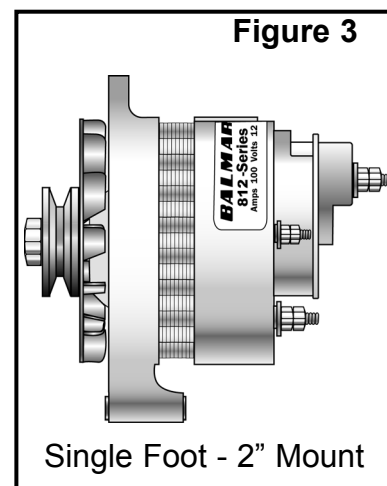
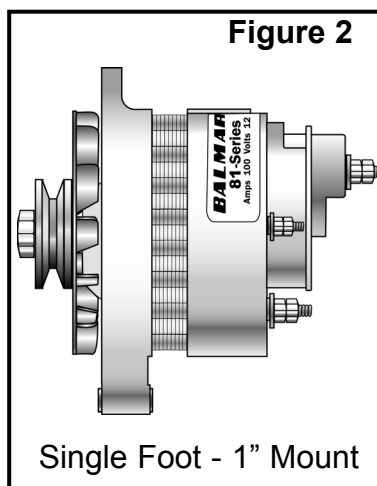

- c. **Blue (B)** Field Wire: Attaches to the positive field terminal on the alternator as shown in **Figure 5**.
- d. **Red (R)** Sensor Wire: Attaches to the positive terminal of the battery, positive output of the alternator, common terminal of the battery switch, or the battery side of an isolator (if used).
- e. **White (W)** Stator Wire: Attaches to the Stator terminal on the alternator as shown in **Figure 5**. If an electric tachometer is used, an additional white wire should be run from the other stator terminal to the tachometer as shown in **Figure 4**.
- f. **Black (Bk)** Ground Wire: Attaches to the negative ground terminal as shown in **Figure 4**.
7. Once the wiring is connected, attach the regulator to the alternator by bolting the angled tab at the bottom of the regulator to one of the 1/4" head bolts located next to the cover plate at the back of the alternator (as shown on the inset in **Figure 4**).
8. Once the regulator and control wires are in place, the alternator's positive output and negative ground cables should be attached. Positive output cable should be connected at the bolt shown on **Figure 4**. The other end of the cable should be connected to the positive terminal of the battery, or the common output terminal of the battery switch if used with multiple battery banks. Refer to the Voltage Loss Table (**Figure 1**) to determine proper cable gauge.
9. The ground cable must provide a sure connection to the batteries' negative terminal. This can be accomplished by grounding the alternator directly to the negative battery terminal or to your engine's grounding bolt. Be sure your cabling is the same size as that of the positive output.

Smart Regulator Wiring

Should you choose to upgrade your system to include the intelligent, microprocessor controlled Max Charge regulator or other BALMAR models, use **Figure 5** as your wiring guide. In addition to its smart charging capabilities, the Max Charge regulator has the unique ability to automatically monitor battery and alternator temperatures and compensate for temperature changes outside of normal values (when used with optional temperature sensors). To install the alternator temperature sensor:

1. Attach the positive and negative wires to the Alternator temperature Sensor terminals on the Max Charge regulator (see the Max Charge manual for terminal locations).

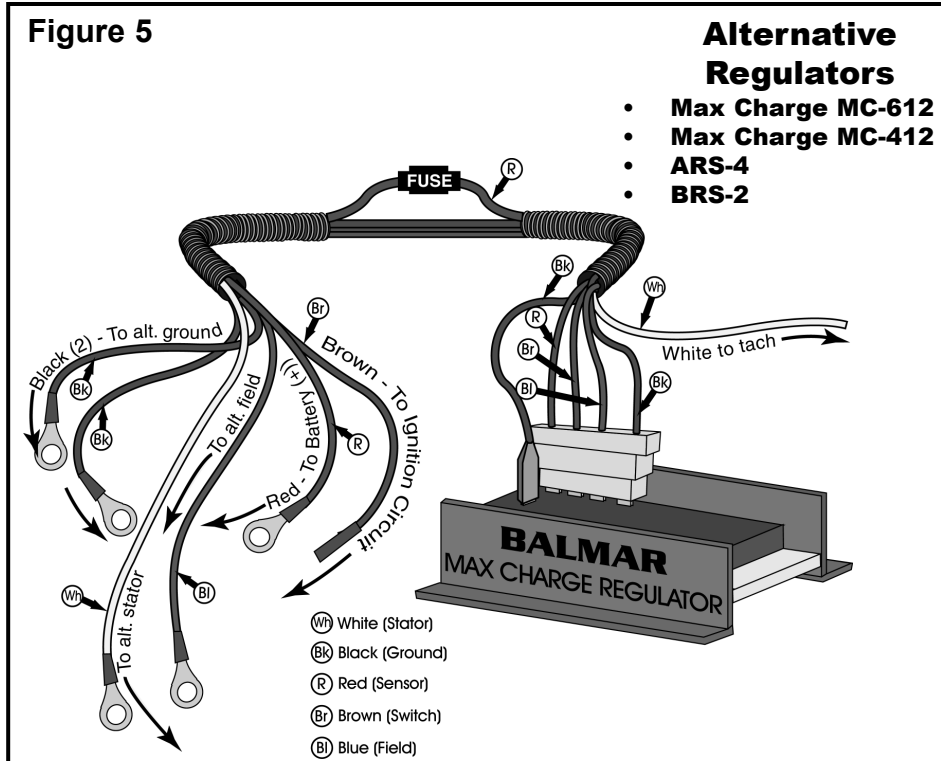
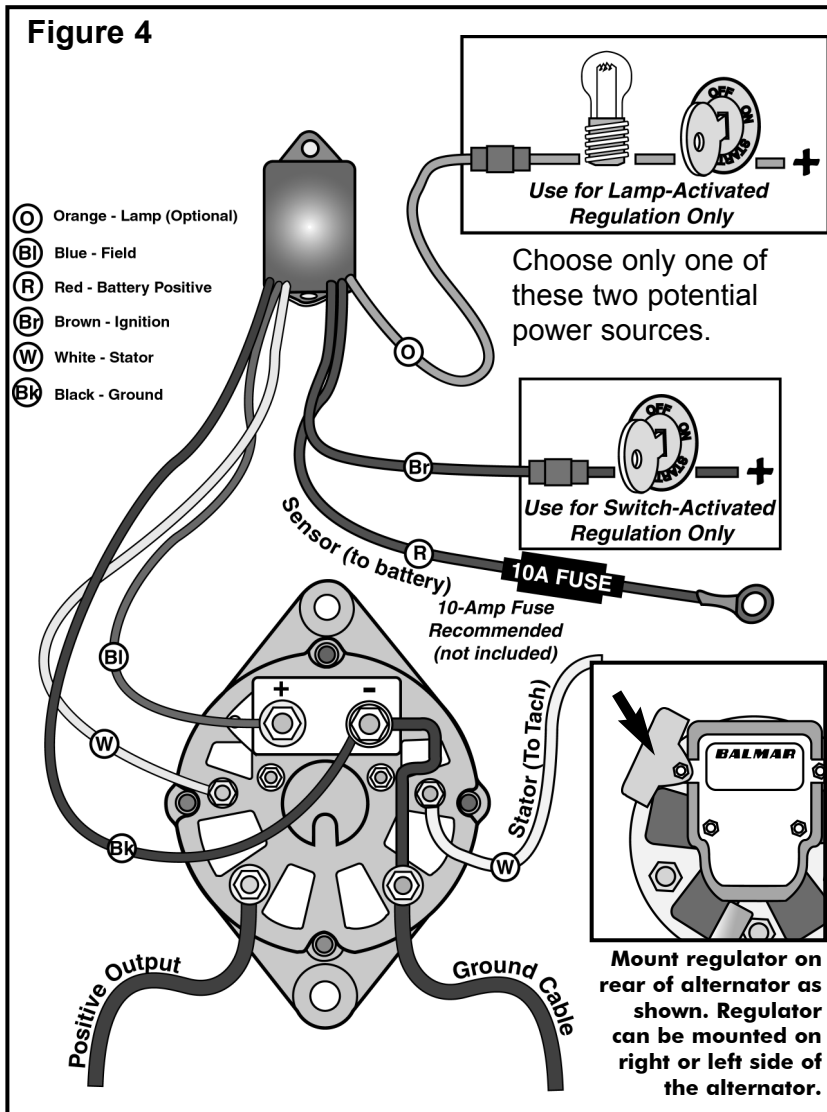

2. Attach the heavy lug terminal to the mid case mount on your alternator. Due to the number of alternator configurations, some installations may vary.

Pulley Attachment

After the alternator is installed and the wiring connections are attached, inspect the pulley for proper tension. When changing pulleys or when using the factory-installed pulley, torque the shaft nut to 50-60 foot-pounds. The shaft nut measures 15/16". To install the belt:

1. Loosen the adjustment arm bolt and alternator pivot assembly bolt.
2. Fit a new, high-quality belt over the appropriate pulleys.
3. Tension the alternator until the belt is securely tightened in place. Re-tighten the pivot assembly and tension arm bolts. To test tension, place a 15/16" wrench on the alternator shaft nut and apply pressure. If the pulley rotates without moving the belt, re-loosen the bolts, apply additional pressure and re-tighten. Repeat until the belt is properly tensioned. (See **Figure 6**.)

When installation is complete, run the engine. Visually inspect the engine, while running, for evidence of poorly aligned pulleys and belts. Use caution to avoid hot or moving parts. Turn off the engine after approximately 15 minutes and re-inspect the belt tension.

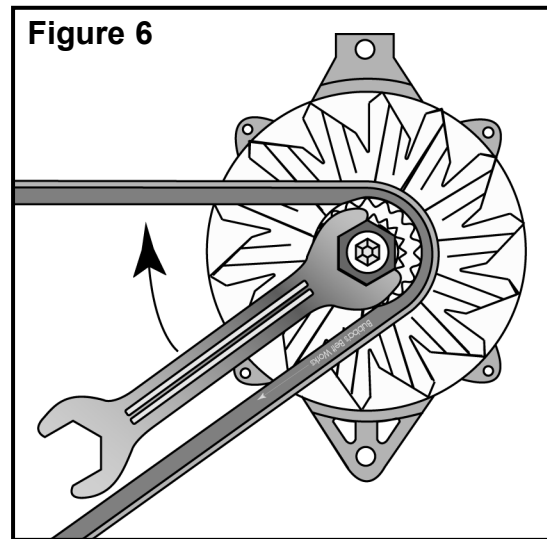

V. ADDITIONAL INSTALLATION INFORMATION

Battery Isolators

Battery isolators may be used with any BALMAR® alternator. Its capacity must equal the maximum alternator output. To compensate for volt drop, sensing must be on the battery side. If a dual-output alternator is used for more than two battery banks, each output must have its own dedicated isolator.

Meters

Most standard in-line Amp meters are UNDER-RATED for our alternators and should be removed from the system. Replace your existing amp meter with a standard volt meter. Should you wish to read output Amps, a high capacity 0-100 or 0-200 amp external shunt-type meter should be installed. Digital meters like the Link 10 or Link 20 by Heart Interface are excellent tools for charging system monitoring.

Tachometers

The alternator tachometer is energized by the pulse frequency generated by the alternator, which in turn is dependent on the alternator's rotor speed. BALMAR® 80-Series alternators feature 12-pole construction. Most standard tachometers are engineered for engines with alternator pulley to crankshaft ratios of 1.8 to 2.8 to 1 on alternators with 12 poles.

The AC terminal or stator terminal may be used for electric tachometers not equipped their own sending unit. Tachometers will have to be adjusted and calibrated as necessary. We suggest running the engine up to a cruise RPM (2000), marking the throttle position BEFORE the original alternator is disconnected. After the installation is complete, run throttle up to mark and set the tachometer to its appropriate RPM. If you cannot set your existing tachometer, a programmable tach like the Teleflex Model 82430P should be considered as a replacement. Should bouncing of the tachometer be observed when the batteries are fully charged, turning on some DC loads will often cure the problem.

Output Connections

The most efficient output connection is a direct wire between the alternator and the battery. If your battery switch is closer to the alternator than the batteries, you may connect the output cable to the common output terminal. DO NOT turn the battery switch off when the engine is running. Severe damage to the diodes and the regulator could result.

Fusing

Proper fusing of the charging system is required by ABYC standards. BALMAR® recommends that the alternator outputs be protected by a fuse or manual reset circuit breaker. BALMAR® 75, 100 and 150-amp circuit breakers are available at your local marine supply or may be special ordered through BALMAR®. (See **Figure 7**.) If the alternator is connected directly to the battery, the breaker should be located close to the battery terminal.

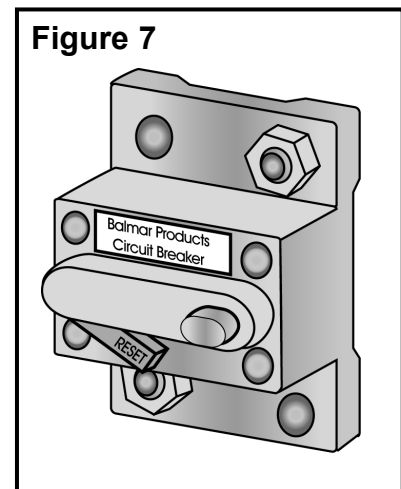

VI. TROUBLESHOOTING

Determining the causes of failures in an electrical system is usually a "trial and error" process. We recommend that you begin your search by determining if the failure can be attributed to one or more of the most common causes of charging system failure: damaged wiring, damaged connectors, worn or damaged belts, worn or overly sulfated batteries, or bad grounds.

A general inspection of the following conditions prior to testing will ensure the accuracy of your test results. Before testing:

1. Remove and clean all charging system electrical connections (this includes the ground side). Also check the harness for resistance. The wires or terminals may become corroded and need to be cleaned or replaced.
2. Charge all batteries to their proper fully charged state and determine if they are serviceable. If your batteries are flooded-type, use your hydrometer to determine their condition.
3. Check and tighten alternator belt. If the belt shows signs of wear or damage, now is an ideal time for replacement. Always replace existing belts with the finest quality replacements available.

After determining that your batteries and wiring are in suitable condition, use the following tests to determine if charging problems are a result of a faulty alternator or regulator. The following tests provide an opportunity to isolate the alternator, regulator and wiring harness in order to determine which component may be malfunctioning. *If you are using the Max Charge regulator, please refer to the troubleshooting instructions included in the Max Charge's instruction manual.*

Regulator Field Test

The following tests are intended to help determine what part of your charging system may be experiencing difficulties. When testing voltage, ensure that your voltmeter is adjusted to its 12V setting. Use the space below the "Expected Reading" to keep track of your own readings.

First Test (Engine Off) - The functionality of the regulator, harness and alternator can be tested by determining if a magnetic field exists at the alternator's pulley shaft. To test:

1. With the ignition in the OFF position, place the head of a steel screwdriver near the nut on the pulley shaft. There should be no evidence of a magnetic field pulling the screwdriver toward the alternator.
2. With the ignition in the OFF position and your voltmeter's negative probe applied to the alternator's grounding bolt, check for voltage on the RED (sensing), BLUE (field) and BROWN (ignition) wires by inserting the positive lead of the voltmeter alongside each wire at the terminal at the back of the alternator or (in the case of the brown wire) at an applicable wire connection. The voltmeter should read:

	Red Wire	Brown Wire	Blue Wire
Expected Reading	12 V *	0 V	0 V
Your Reading			

* 11.5 - 12.8 VDC battery voltage at rest (no charging occurring). If your batteries are isolated and your RED (sensing) wire shows voltages other than those shown above, make sure that the wire is connected on the "battery" side of the isolator. The RED wire must "see" the battery directly.

3. Once you have measured voltage at the three wires and have determined that there is no magnetic field at the pulley shaft or rear bearing, turn your ignition switch to its ON position (without turning on the engine). If your regulator is activated by an oil pressure switch, turn on your engine (Caution: if the engine must be run during these tests, use extreme caution to avoid contact with moving parts or hot engine or alternator surfaces.)
4. Place the head of a steel screwdriver near the nut on the pulley shaft. DO NOT attempt this test with the motor running! There should be evidence of a magnetic field pulling the screwdriver toward the alternator. If magnetic field is present, the regulator is working properly, as well as the alternator's rotor and brushes.
5. With the ignition in the ON position (engine not running - except in cases of oil pressure switched circuits) measure the voltage at the same three wires as before. The voltmeter should read:

	Red Wire	Brown Wire	Blue Wire
Expected Reading	12 V*	12 V	7 - 12 V
Your Reading			

* 11.5 - 12.8 VDC battery voltage at rest (no charging occurring). If your batteries are isolated and your RED (sensing) wire shows voltages other than those shown above, make sure that the wire is connected on the "battery" side of the isolator. The RED wire must "see" the battery directly.

Once the voltage is measured with the ignition on and the engine off, the engine can be started for the final regulator test. To collect your final readings:

1. With the ignition in the ON position and the engine running, measure the voltage readings at the Red, Blue and Brown wires. The voltage values should read as follows:

	Red Wire	Brown Wire	Blue Wire
Expected Reading	12 - 14V**	12 V	4 - 12 V
Your Reading			

** 13.5 - 14.5 VDC battery voltage when charging.

This completes the regulator test. If the voltages measured at your regulator match those target readings shown in the tables above, and if the alternator produces a magnetic field, the regulator and harness are working correctly. The presence of a magnetic field is also an indicator that the alternator rotor and brushes are functioning correctly. If one or more of the voltage readings are substantially different than the target readings shown above, the regulator or harness may be damaged or defective.

Alternator Field Test

By eliminating the regulator from the charging circuit, it is possible to determine if charging failure is caused by the alternator. Testing the actual output of the alternator is known as "Full Field Testing". This can be accomplished by jumping a positive 12VDC current to the field terminal at the rear of the alternator. This test eliminates both the regulator and the harness, making it easier to isolate your investigation to the alternator. CAUTION: Voltage is unregulated during this test and could damage sensitive electronics. Ensure that all voltage sensitive equipment is turned off and any connections between the alternator and the regulator are disconnected prior to starting the engine. To test the alternator:

1. Disconnect the BLUE (field) wire from the alternator. Attach shielded alligator clips to both ends of a test wire.
3. Attach one end of the test wire to the alternator's field terminal and attach the other end to the positive output of the alternator (see **Figure 8**). (If an isolator is used, jump to the field from the battery side of the isolator.) CAUTION: Do not allow the wire to contact the case while it is attached to the positive post.
4. The motor should be run long enough to determine that charging voltage is present. Unregulated voltage can rise quickly. Do not allow extended unregulated charging to occur without carefully monitoring voltage levels.

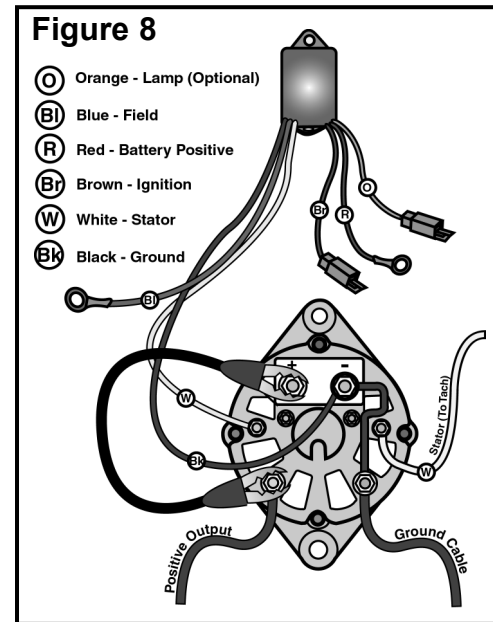

If the alternator fails to generate voltage during full field testing, an alternator malfunction is likely. Contact your local alternator repair shop or Balmar's technical service staff for recommendations.

Conclusion

If your readings differ substantially from the "Expected Readings" listed in the charts above, the regulator may be malfunctioning, or there may be a continuity problem. Contact our technical support staff at (360) 435-6100. Keep your recorded readings in the spaces provided below the "Expected Readings" so you can share them with the technical support person.

If the preceding tests do not prove the existence of a failure within the regulator or alternator, we recommend you contact a licensed marine electrician who can test your system for wiring and circuit damage or other system failures that could be responsible for charging difficulties. If you determine that repair service is necessary for either your alternator or regulator, please gather the following information before contacting our service technicians.

1. Model of alternator.
2. Model of voltage regulator.
3. Voltage readings on red, brown and blue wire at regulator with engine off, key on.
4. Voltage readings on red, brown and blue wire at regulator with engine running at a fast ideal 1400 rpm.

VII. LIMITED PRODUCT WARRANTY

BALMAR warrants to the original consumer/purchaser the product is free from any defects in material or workmanship for a period of one year from the date of purchase. If any such defect is discovered within the warranty period, BALMAR will replace the regulator free of charge, subject to verification of the defect or malfunction upon delivery or shipping prepaid to BALMAR.

This warranty DOES NOT apply to defects or physical damage resulting from abuse, neglect, accident, improper repair, alteration, modification, or unreasonable use of the products resulting in breakdown, cracked or broken cases nor are parts damaged by fire, water, freezing, collision, theft, explosion, rust, corrosion or items damaged in shipment in route to BALMAR for repair. BALMAR assumes no responsibility for consequential damage or loss or expense arising from these products or any labor required for service or repair.

BALMAR WILL NOT repair or be held responsible for any product sent without proper identification and return address or RA number clearly marked on the package. You must include proof of date and place of purchase (photocopy of purchase invoice) or we cannot be responsible for repairs or replacement. In order to expedite warranty claims more efficiently, BALMAR asks that prior to returning a defective product for repair, you call their customer service department for a warranty return authorization number.

If factory service is required, you can contact our BALMAR Customer Service Department Monday through Thursday, 7:30 AM to 5:30 PM, (PST) 1-360 435-6100 ext "3".

Material required for the repair or replacement for the defective part or product is to be supplied free of charge upon delivery of the defective regulator to BALMAR, 19009 61st Ave. NE, Arlington, WA 98223. Customer is responsible for all return transportation charges and any air or rush delivery expense. BALMAR reserves the right to determine whether to repair or replace defective components.

THE ABOVE LIMITATIONS MAY NOT APPLY TO YOU. SOME STATES DO NOT ALLOW LIMITATIONS ON HOW LONG AN IMPLIED WARRANTY LASTS. NO PERSON, AGENT, DEALER IS AUTHORIZED TO GIVE ANY WARRANTY

BALMAR 19009 61st Ave. NE, Arlington, WA 98223 Ph: (360) 435-6100, Fx: (360) 435-3210

E-mail: balmar@balmar.net, Web: www.balmar.net

VIII. QUICK INSTALLATION BASICS

CAUTION: This BALMAR® marine alternator is intended for installation by a qualified marine electrician. If you are not experienced at marine electrical installations, we strongly recommend investing in the services of a qualified technician. The following is a brief description of a typical alternator installation. Your installation may vary based on engine type and age. This basic guide is meant for quick reference and should not be used without first reading the rest of the manual. To install the alternator:

1. Turn off the battery and disconnect the ground wire. Disconnect the wiring from the existing alternator.
2. Loosen the mounting bolt and remove the existing alternator.
3. Compare existing mounting points to those on your new BALMAR® alternator. In most applications, the new alternator will replace the existing alternator without any modification. Some cases may require some bracket modification. BALMAR® offers a universal mounting arm which may solve some mounting challenges. Others can be obtained through your local auto or marine supply.
4. Attach the mounting foot of the new alternator to its engine mount. Some shimming may be necessary to ensure a secure mount.
5. Inspect to ensure proper pulley alignment. If your belt also drives the water pump, ensure all pulleys are properly aligned.
6. Your alternator is shipped with a simple, single-stage regulator. The wiring is arranged as follows:
 - a. **Brown (Br)** Ignition (source) Wire: Attaches to the auxiliary side of the vessel's ignition switch, or an isolated ground oil pressure switch to turn on the regulator. Used when the orange wire is NOT used.
 - b. **Orange (O)** Lamp Wire: This wire provides power to the regulator when connected to a warning lamp (optional). Used when the brown wire is NOT used.
 - c. **Blue (B)** Field Wire: Attaches to the positive field terminal on the alternator as shown in **Figure 9**.
 - d. **Red (R)** Sensor Wire: Attaches to the positive terminal of the battery, positive output of the alternator, common terminal of the battery switch, or the battery side of an isolator (if used).
 - e. **White (W)** Stator Wire: Attaches to the Stator terminal on the alternator as shown in **Figure 9**. If an electric tachometer is used, an additional white wire should be run from the other stator terminal to the tachometer as shown in **Figure 9**.
 - f. **Black (Bk)** Ground Wire: Attaches to the negative ground terminal shown in **Figure 9**.
7. Once the wiring is connected between the regulator and the alternator, the alternator's positive output and negative ground cables should be attached. Positive output cable should be connected at the the bolt shown on **Figure 9**. The other end of the cable should be connected at the positive terminal of the battery. If your battery switch is closer to the alternator than the batteries, you may connect the output cable to the common output terminal. Refer to the Voltage Loss Table (**Figure 1**) to determine proper cable gauge.
8. The ground cable must provide a sure connection to the batteries' negative terminal. This can be accomplished by grounding the alternator directly to the negative battery terminal or to your engine's grounding bolt. Be sure your cabling is adequately sized to match your amperage load.

CAUTION: Always follow the safety guidelines outlined on Page 1.

