

71C-72C & V Drive  
(All Ratios)

**MARINE  
TRANSMISSION  
OWNER'S MANUAL**

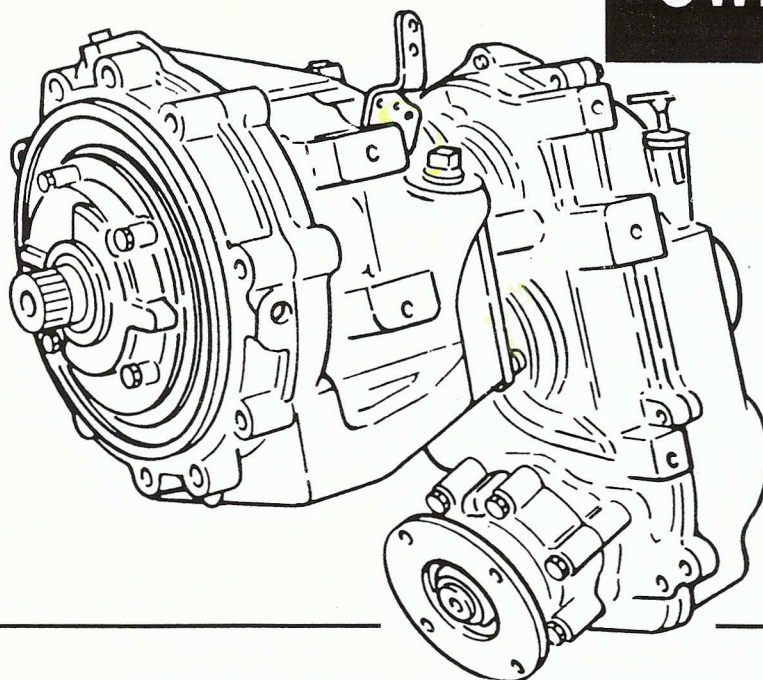

***Velvet Drive***<sup>®</sup>  
TRANSMISSIONS

Division of Regal-Beloit Corporation

P.O. Box 238

1208 Old Norris Road

Liberty, SC 29657

Phone (864) 843-9234 Fax (864) 843-1276

[www.velvetdrive.com](http://www.velvetdrive.com)

## Table of Contents

SECTION		PAGE
I	General Information .....	1
II	Launch Maintenance .....	3
III	Operation .....	7
IV	Winter Storage .....	7
V	Troubleshooting .....	8
VI	Warranty .....	9
VII	Maintenance Record .....	10

### Owner's Responsibilities...

It is the owner's/operator's responsibility to perform the necessary safety checks to ensure that all lubrication, cooling, maintenance and recommended practices are followed for safe, enjoyable operation.

Proper care and maintenance will only help ensure long service life from your Velvet Drive® transmission.



## SECTION I GENERAL INFORMATION

1-1. Every Velvet Drive® marine transmission is self-contained, having its own sump and hydraulic pump separate from the engine. The gear driven pump affords assurance of positive lubrication.

1-2. The Velvet Drive® In-Line hydraulic transmission is available in two (2) models with numerous final drive ratios suitable for inboard pleasure and work boats.

1-3. Two (2) V-Drive transmission models will accommodate twin screw applications using engines with the same rotation.

1-4. The identification tag that appears on these Velvet-Drive® transmissions is located on the top of the left-hand transmission mount and contains valuable information concerning the transmission. This information is as follows:

- a. **Model Number** — This appears below the words "Velvet Drive."
- b. **Ratio** — The gear ratio appears in the left-center of the identification tag.
- c. **Serial Number** — Appears at the right-center under the model number.

1-5. Transfer the information on your identification tag to the Maintenance Record Chart on page 10 of this manual. Additionally, the color of the identification tag should be noted in the appropriate space and the date placed in operation.

1-6. The model number and serial number is required on all correspondence.

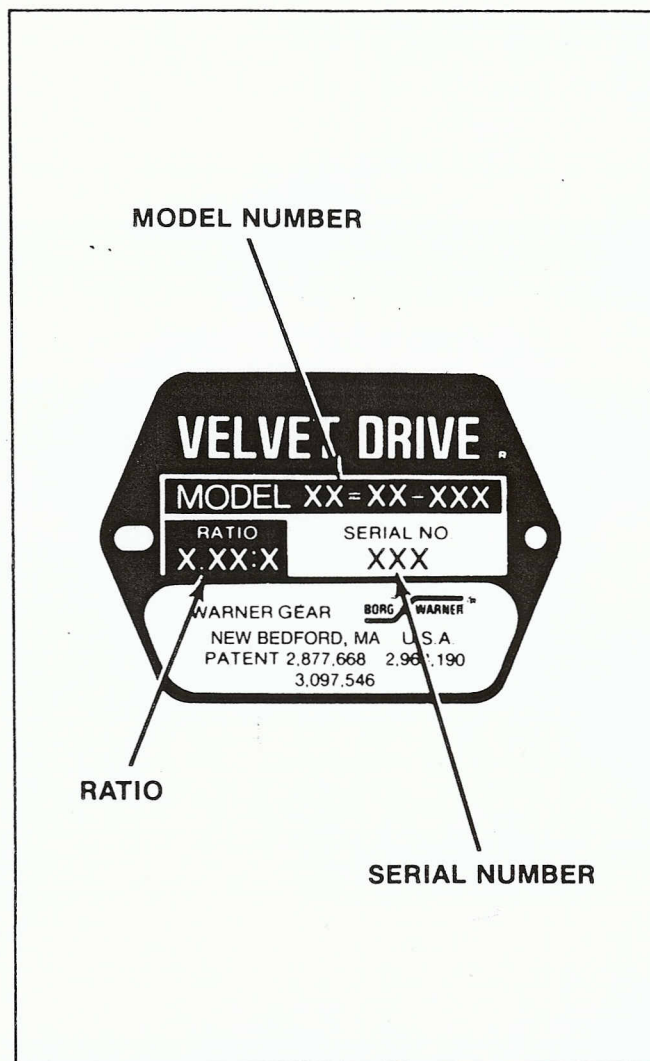

Figure 1-1. Identification Tag

Table 1-1. General Specifications

Model	Ratios*	Fluid Capacity** Qts./Liters	Dry Weight Lbs./Kgs.
10-04	1.21:1 thru 2.50:1	4/3.8	190/86.2
10-05	1.21:1 thru 2.50:1	4/3.8	203/92.1
10-17	1:1	2/1.9	95/43.1
10-17	1.52:1 thru 2.91:1	3/2.8	145/65.8
10-18	1:1	2/1.9	109/49.4
10-18	1.52:1 thru 2.91:1	3/2.8	154/69.9

\* Gear ratios vary depending on model number.

\*\* Fluid capacity is approximate and depends on installation angle and cooling system.

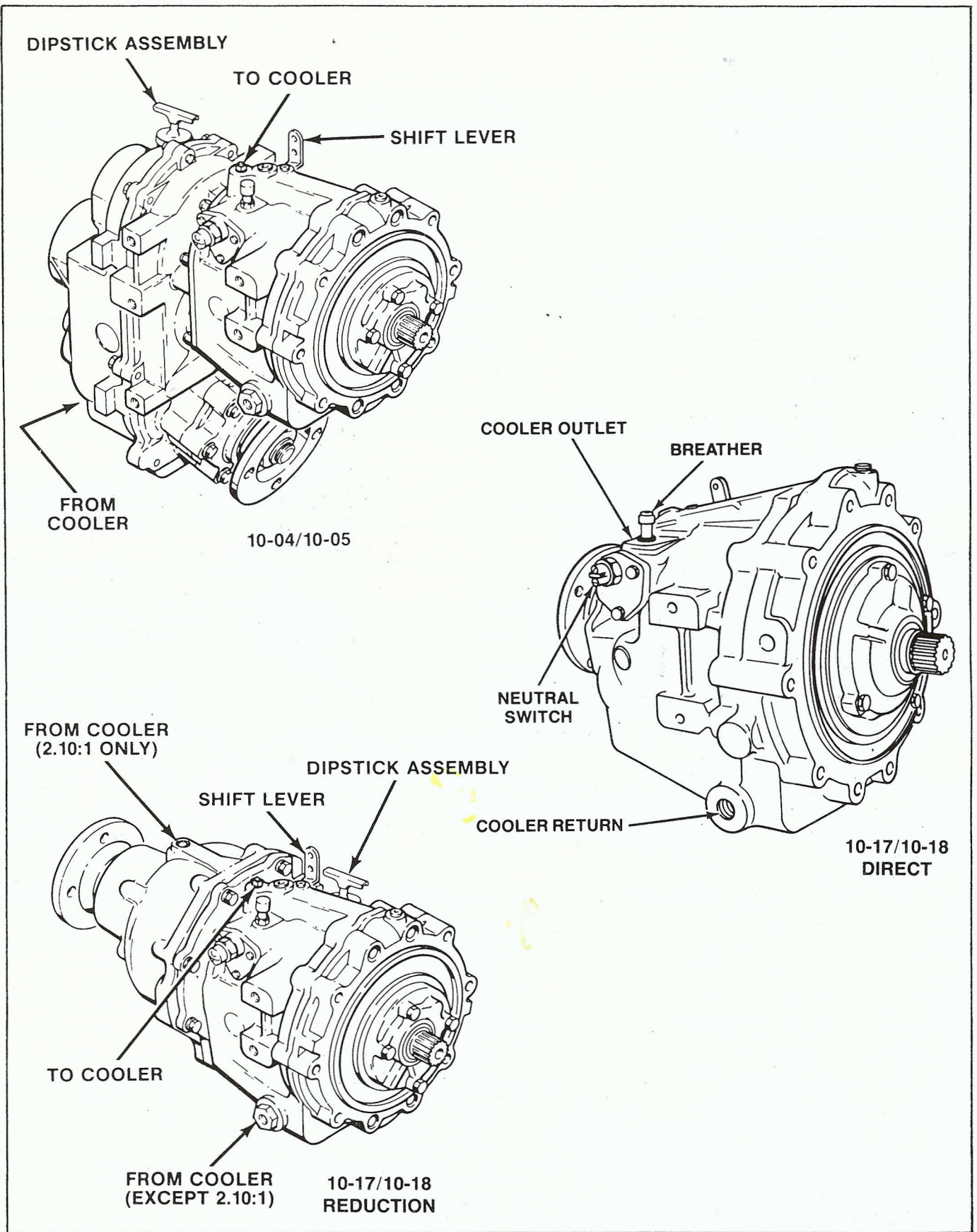

Figure 1-2. General View of Velvet Drive<sup>®</sup> Transmissions



## SECTION II LAUNCH MAINTENANCE

2-1. The following maintenance should be performed after launching your boat to ensure optimum performance and life from your Velvet Drive<sup>®</sup> transmission.

### CAUTION

Vibration, gear noise, loss of rpm and premature oil seal and bearing failure can be caused by misalignment of propeller shaft coupling and transmission output coupling flange.

2-2. Propeller shaft coupling flange and transmission output flange alignment is performed after launching of your boat as well as any time your boat strikes a heavy object or after your boat has been hoisted or pulled from the water.

### CAUTION

Remove attaching hardware from transmission output flange and propeller shaft coupling flange before removing boat from water and separate flanges.

2-3. Check the alignment of the transmission output flange and propeller shaft coupling flange using the following procedure with boat in water:

- a. Disconnect the battery.
- b. Remove attaching hardware from coupling flanges.
- c. Check clearance around coupling flanges with .003 feeler gage and flange pilot engaged.
- d. Rotate coupling flanges together one complete revolution, stopping every 90° to check clearance with .003 feeler gage.
- e. Alignment is satisfactory when the transmission output flange and propeller shaft coupling flange with pilot seated are within .003 inch (.076mm) of parallel.
- f. If alignment is unsatisfactory, an adjustment is required (see paragraph 2-4).
- g. When alignment is satisfactory, tighten attaching hardware.

2-4. Propeller and Output Shaft Adjustment

### CAUTION

Do not lift or pry against transmission output flange or coupling to move engine.

This adjustment is accomplished at the boat motor and transmission mounts **ONLY**. This procedure should be accomplished by a skilled marine mechanic.

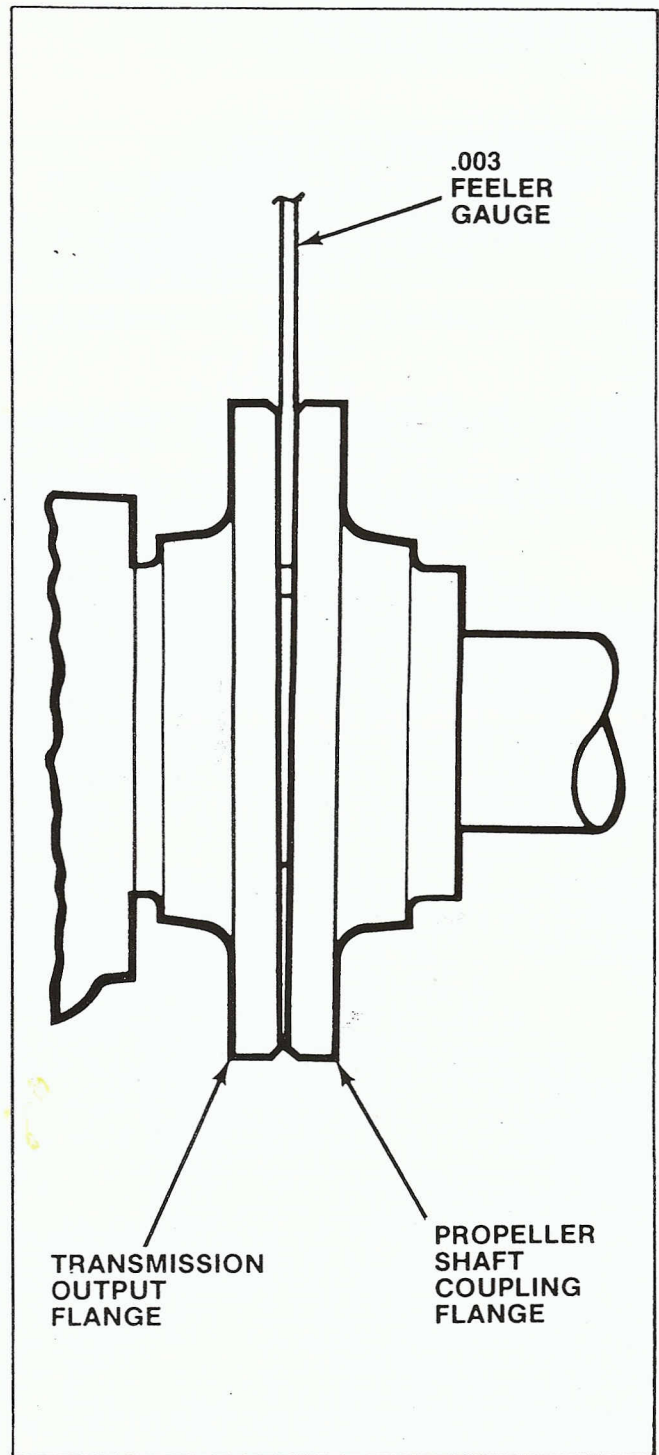

Figure 2-1. Coupling Shaft Alignment

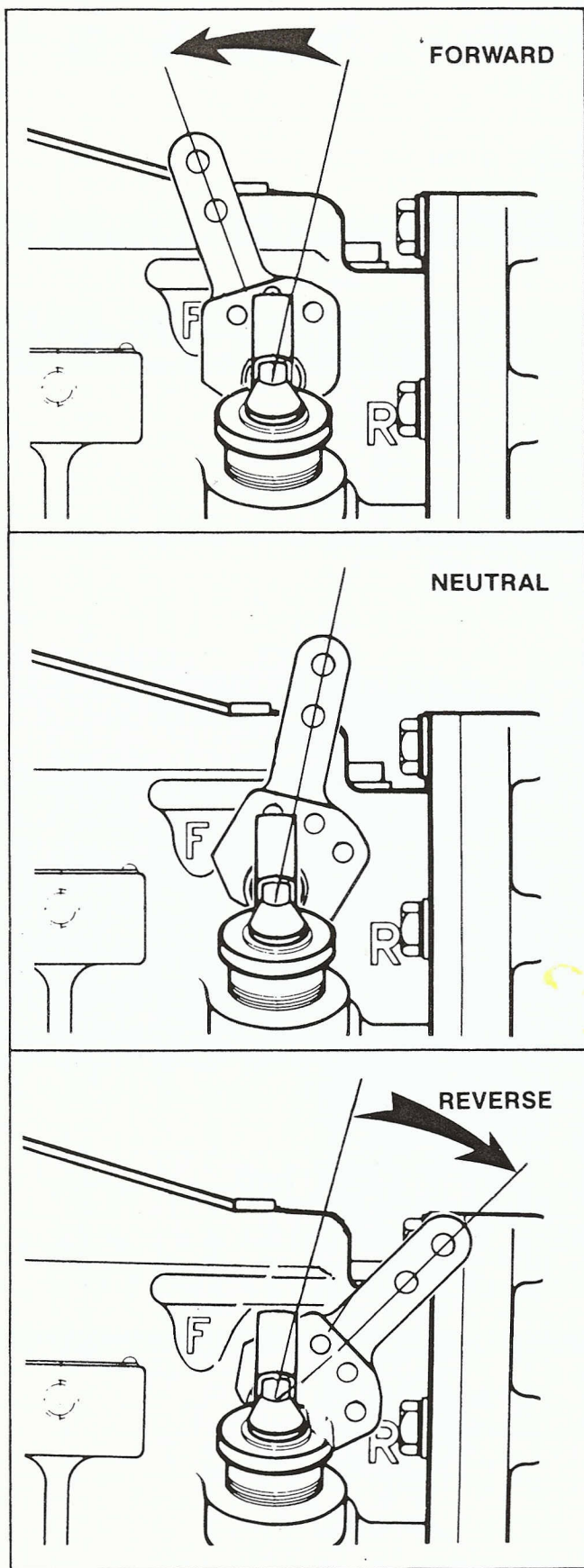

Figure 2-2.  
Transmission Shift Lever Positions

#### 2-5. Shift Lever Positioning

The selector control mechanism and linkage must position the shift lever on the transmission exactly in Forward (F), Neutral (N), and Reverse (R) shifting positions. A detent ball located behind the transmission shift lever must work freely to center the lever in each position. (see Figure 2-2). The selector control positions at the helm(s) must be coordinated with those of the Velvet Drive® shift lever through shift mechanism adjustments. An improperly adjusted shift mechanism can cause damage to the transmission.

**NOTE:** When moving from Neutral Position to:  
Forward is always towards engine.  
Reverse is always away from engine.

#### CAUTION

**Clutch failure will occur if transmission shift lever does not fully engage detent ball positions.**

The shifting mechanism and transmission shift lever should be free of dirt to ensure proper operation.

#### CAUTION

**Do not remove detent ball.**

#### 2-6. Transmission Connections

- a. Visually check for oil leaks at hydraulic connections, worn hydraulic lines.
- b. Check for broken or loose fasteners.
- c. Replace all worn hydraulic lines, tighten all connections where an oil leak has occurred, and secure all hydraulic lines.
- d. Visually check all electrical connections for loose terminals and worn wires.
- e. Repair or replace all worn or broken wires to U.S. Coast Guard specifications and tighten all loose connections.

#### 2-7. Transmission Bolts

- a. Check all exterior transmission bolts for tightness.
- b. Tighten all loose bolts to recommended torque specifications.
- c. Tighten all coupling bolts.

#### 2-8. Change Transmission Oil

A seasonal transmission oil change is recommended for all pleasure boats. Work boats require transmission oil changes every 1,000 hours. Oil must be changed anytime it becomes contaminated, changes color, or becomes rancid smelling.

#### WARNING

**Do not use gasoline or any other volatile or highly combustible liquid as a solvent.**



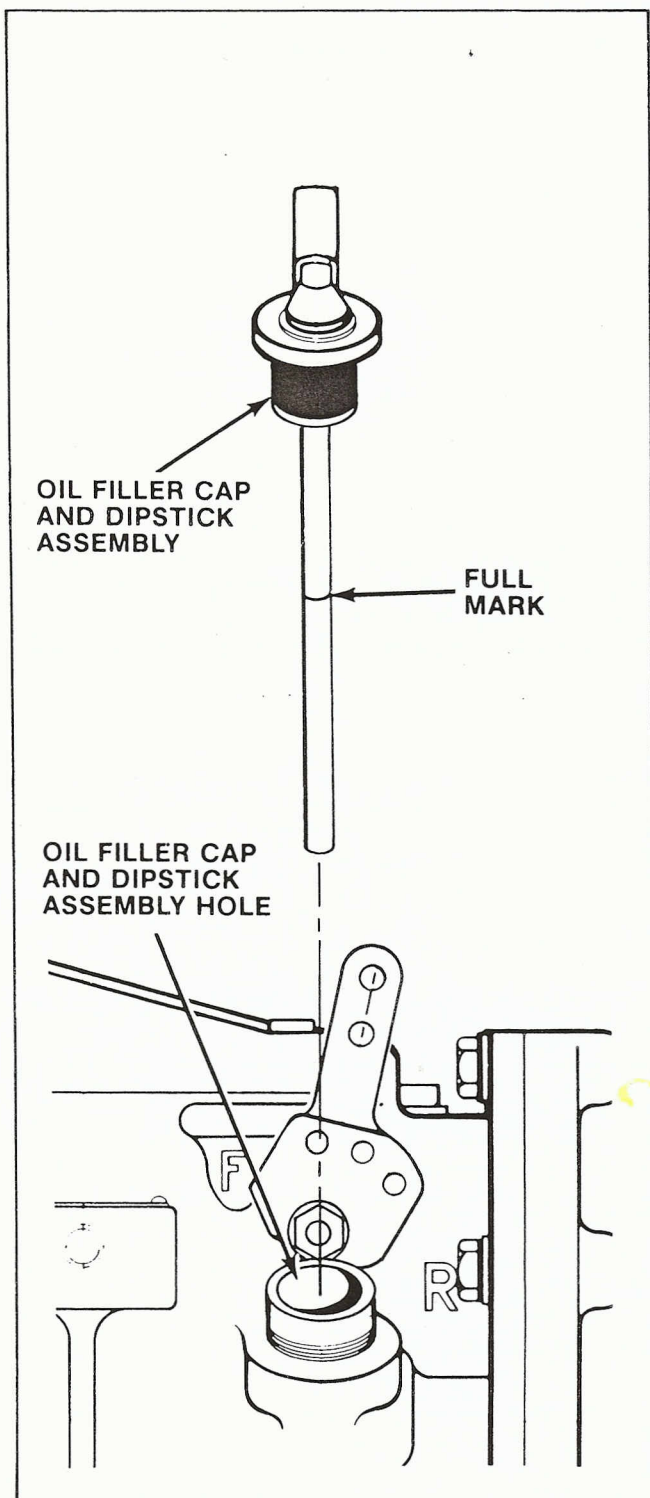

Figure 2-3. Dipstick Assembly

- 2-9. Removing Transmission Oil (Oil Filler Cap)
  - a. Place an appropriate size container near oil cooler return line.
  - b. Remove oil filler cap and dipstick assembly (see Figure 2-3).
  - c. Remove oil cooler return line.
  - d. Allow oil from return line to drain into container.
  - e. Connect oil cooler return line and torque to 25-35 ft.-lbs. (34-47 N·m).
  - f. Use a suction pump in the oil filler cap hole to remove remaining oil in the transmission.
  - g. Remove suction pump from transmission.

#### 2-10. Fill Transmission With Oil

The quantity of oil depends upon the model Velvet Drive® (see Table 1-1 for capacity) angle of installation and oil cooling system capacity.

**NOTE:** Oil capacities in Table 1-1 are for transmission only. Additional oil will be required for oil cooling system.



**WARNING: DO NOT REMOVE DIPSTICK WITH ENGINE RUNNING. HOT OIL CAN CAUSE BURNS.**



**CAUTION: Clean around the area of the dipstick, before removing. Small particles of dirt can cause damage to internal components and cause valves to stick.**

#### Check Oil Level.

The transmission should be at operating temperature (190° max.) to get an accurate oil level reading. Oil will expand when it is heated. Oil will drain back from the cooler. Expansion and drain-back can significantly affect oil level.

#### Warm Oil Level Check.

When the transmission is at operating temperature, place selector lever in neutral. Shut off engine. Carefully remove transmission dipstick. Immediately insert clean dipstick and read oil level.

**NOTE:** Oil level must be checked immediately after engine shut-down to prevent an incorrect reading. Oil drains back into transmission from the cooler and cooler lines.

Add or remove oil if necessary. Repeat the above checking procedure as required until oil is at the dipstick mark.

#### Cold Oil Level Check.

For ease of checking the oil prior to engine start-up, a cold oil level mark can be made. To find the cold oil level mark, the oil level must first be set according to the warm oil level checking procedure. Then, let the boat sit overnight. Insert clean dipstick and read oil level.

Put a mark on the dipstick at the cold oil level reading.

You can use the new mark to check the oil level when cold. If oil level adjustment is needed, add oil to the new mark.

#### CAUTION

**System related noises or vibrations can occur at low engine speeds which can cause gear rattle resulting in damage to the boat engine and/or transmission. Velvet Drive Transmission is not responsible for total system related torsional vibrations of this type.**

2-11. Service manuals can be obtained by contacting the nearest Velvet Drive® distributor.

#### TYPE OF OIL

TRANSMISSION FLUID. General Motors Dexron III, Ford Mercon, Daimler-Benz 236.6 or any SAE 10 hydraulic oil that meets Allison C3, Caterpillar TO-2 or equivalent specification is recommended.

#### NOTE:

Because of the continuous development of oil formulation, some high performance applications may result in foaming and leakage from the transmission's vent. Under these circumstances, Velvet-Drive suggest using oils meeting Allison C3 or Caterpillar TO-2 specifications. In addition, it may be necessary to experiment with the fluid level in these applications.

Do not mix different brands or types of oil.

If the transmission oil temperature has exceeded 190 degrees Fahrenheit or if the transmission alarm sounds, the oil must be changed.

Any changes or modifications to the transmission cooling system may require the oil level be readjusted.

Any additions to the boat which will change the installation angle of the transmission at rest (such as extra fresh water tanks, fuel supply, etc.) may require an oil level adjustment.



## SECTION III OPERATION

3-1. Perform all preoperation maintenance on the Velvet Drive<sup>®</sup> transmission (see paragraph 2-12).

3-2. At the helm place transmission selector control in Neutral before starting engine. Shifts from any selector position to any other selector position may be made at any time below 1000 rpm and in any order. Shifts should be made at the lowest practical engine speed.

### CAUTION

**Shifting above 1000 rpm can severely damage boat, transmission and engine.**

- a. **Neutral** — Move selector lever to the middle position. You should feel the detent center the shift lever on the transmission through the linkage to the selector lever. With the control in this position, hydraulic power is completely interrupted and the output shaft of the transmission does not turn.
- b. **Forward** — Move selector lever to the forward position. You should feel the detent. The shift lever on the transmission in the forward position. The output shaft and the propeller should move the boat in a forward direction.

### WARNING

**If boat moves backwards with the selector control in the forward position, shut off engine (see paragraph 2-5) or consult your nearest Velvet Drive<sup>®</sup> distributor.**

**NOTE:** This problem can be a result of improper installation by the boat builder or service facility.

### CAUTION

**Early gear failure will occur when the transmission is operated in reverse to obtain forward propulsion.**

- c. **Reverse** — Move selector lever to the rearward position. You should feel the detent. The shift lever on the transmission is in the reverse position. The output shaft and the propeller should move the boat in a reverse direction.

3-3. Velvet Drive<sup>®</sup> Transmission Operation

- a. Place selector control in the Neutral position.
- b. Start engine and set throttle at idle speed and warm up transmission oil for a few minutes.
- c. Be aware of any unusual noises or vibrations and investigate to determine the cause.

### CAUTION

**Before checking oil, shut off engine. Hot oil could cause burns.**

- d. Shut off engine and check transmission oil level and add oil, if required, to the full mark on the dipstick.
- e. Restart engine.

3-4. Freewheeling — It has been determined by tests and practical experience that all Velvet Drive marine transmissions can be freewheeled without risking damage in sailing or trolling applications. Caution should be taken to be sure that proper oil level is maintained prior to freewheeling as well as normal running. Freewheeling one propeller of a twin engine boat at trolling speeds will not cause damage to the transmission connected to the freewheeling propeller.

## SECTION IV WINTER STORAGE

4-1. Storage requires special care. Before winter storage one must:

- a. Disconnect battery.
- b. Drain water from the transmission oil cooling system.
- c. Wipe transmission free of dirt, grime and grease.
- d. Touch up unpainted areas of the transmission using suitable paint.
- e. Loosen attaching hardware from transmission output flange and propeller shaft coupling flange before removing boat from water and separate flanges.

## SECTION V TROUBLESHOOTING

5-1. Velvet Drive® is a self-contained, precision built marine transmission. Should trouble occur, consult Table 5-1 for remedy.

**Table 5-1. Velvet Drive® Troubleshooting**

SYMPTOM	CAUSE	REMEDY
Oil in fly wheel housing.	Unknown.	Service facility.
Oil on transmission.	Loose bolts. Loose fittings. Loose dipstick. Loose drain plug. Unknown.	Tighten to specifications. Tighten, replace. Tighten, replace. Tighten, replace. Service facility.
Oil around retainer.	Retainer bolts loose. Unknown.	Tighten to specifications. Service facility.
Oil and water mixed.	Damaged oil cooler.	Service facility.
High oil temperature.	Oil level low. Oil level high. Dirty oil cooler. Low water level. Unknown.	Add oil. Drain oil to full mark on dipstick. Replace cooler. Fill cooling system. Service facility.
Shifts hard.	Selector control. Linkage. Detent ball. Unknown.	Service facility. Adjust, replace. Clean, lubricate. Service facility.
Slow engagement.	Selector control. Low oil level. Linkage. Detent ball. Unknown.	Service facility. Add oil. Adjust, replace. Clean, lubricate. Service facility.
Boat won't move.	Improper selector position. Low oil level. Propeller missing. Propeller shaft broken. Transmission malfunction. Engine malfunction. Charging pump reversed.	Adjust, replace. Add oil. Replace. Service facility. Service facility. Service facility. Service facility.



## SECTION VII MAINTENANCE RECORD

7-1. Record the model number, ratio, serial number and color of nameplate of your transmission below for future reference.

Velvet Drive®:  
 Model Number \_\_\_\_\_  
 Serial Number \_\_\_\_\_  
 Ratio \_\_\_\_\_  
 Color of Nameplate \_\_\_\_\_  
 Date placed in operation: \_\_\_\_\_  
 Propeller Size \_\_\_\_\_

Velvet Drive®:  
 Model Number \_\_\_\_\_  
 Serial Number \_\_\_\_\_  
 Ratio \_\_\_\_\_  
 Color of Nameplate \_\_\_\_\_  
 Date placed in operation: \_\_\_\_\_  
 Propeller Size \_\_\_\_\_

**Oil Changed**

Date	Date	Date

**Service Record**

Date	Service Required