

## Installation Instructions

### Variable Ratio Alternator & Switching Diesel Tachometer - Tach/Hourmeter

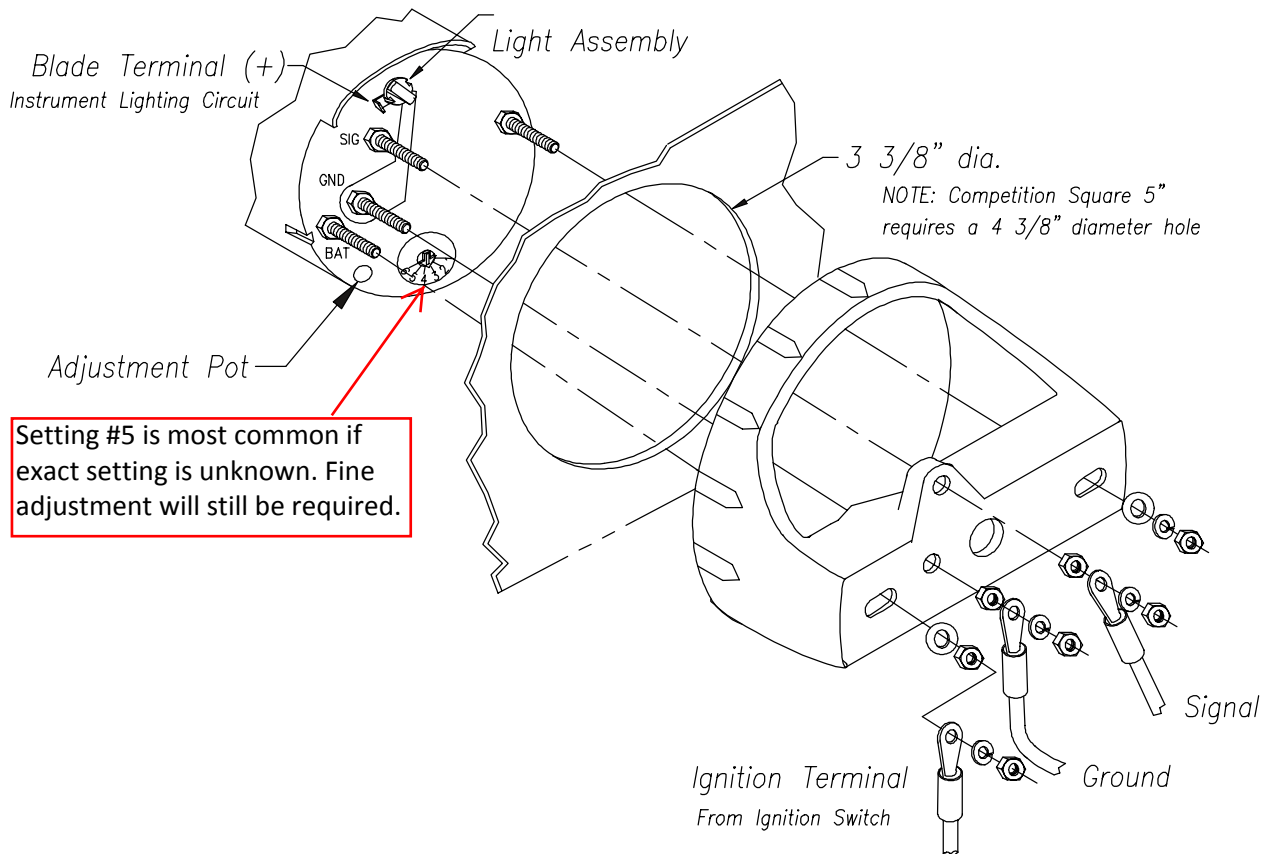

**CAUTION:** Disconnect the battery during installation. Tighten nuts on the backclamp only slightly more than you can tighten with your fingers. Six **inch-pounds** of torque are sufficient. Over tightening may result in damage to the instrument and may void your warranty.

1. Location: The tachometer should be located at least 18" from a magnetic compass. Some interference (erratic operation) may be noticed on the tachometer during radio transmissions. This will neither damage a Faria<sup>®</sup> tachometer nor affect accuracy when not transmitting.

2. Be certain to use stranded, insulated wire not lighter than 18AWG that is approved for marine use. It is recommended that insulated wire terminals, preferably ring type, be used on all connections to the tachometer, except the light, which requires a 1/4" insulated female blade terminal.

~~3. Switching Diesel: The diesel tachometer sender (90901 or equivalent) must be used in conjunction with switching diesel tachometers. One sender will operate two tachometers. Mount the sender to the engine at the mechanical drive take off using the correct drive tip (supplied to properly engage the sender).~~

## CALIBRATION

4. Using a small screwdriver, *SLIGHTLY* depress and turn the selector switch on the back of the tachometer to the correct position to match the engine's tachometer drive take-off ratio (see label on the side of the tachometer). *Depressing the switch too hard may cause damage to the tachometer!* Be sure the selector switch has locked into the detent at the correct position by slightly rotating the switch back and forth with the screwdriver. If the drive ratio or alternator pole count is not known, consult the engine manufacturer and provide them with the correct model, horsepower, and year of manufacture of the engine. Alternator tachometer application will require further calibration as noted in steps 10 - 13. **\*We recommend starting with**

### Position 5 (most common)

5. Cut a 3-3/8" dia hole in the dash and mount the tachometer with the backclamp supplied.

6. Connect a wire to the tachometer stud marked "GND" (ground) and secure with a nut and lockwasher. Connect opposite end to the boat's electrical ground, generally available in several locations at or near the instrument panel.

7. Connect a wire to the tachometer stud marked "BAT" (battery) and secure with a nut and lockwasher. Connect the opposite end to a 12VDC circuit that is activated by the ignition switch.

8. Connect a wire to the tachometer stud marked "SIG" (signal) and secure with a nut and lockwasher.

A.) Switching Diesel:

Connect the opposite end to the gray wire of the diesel tachometer sender. Connect the black wire of the diesel tachometer sender to the engine ground.

B.) Variable Ratio:

Connect the opposite end to the boat's alternator signal output. Consult your engine manual for its location and proper color code.

9. Connect the blade terminal adjacent to the twist-out light assembly to the positive "+" side of the boat's instrument lighting circuit. No separate ground is required for lighting. Reconnect the battery.

10. Remove the weather seal plug located in the hole marked "ADJ".

11. Run the engine at a known RPM over 1000 and nearest to cruise RPM as possible. RPM's can be established with a mechanic strobe light or accurate test tachometer. CAUTION: Do not exceed maximum, recommended RPM.

12. Carefully vary the adjustment pot (through the hole in the case) with a flat blade jeweler's screwdriver, (Some models may have a 5/64ths or 1.4 mm Hex.) until your *Faria*® Marine Instruments tachometer is in agreement with the known RPM.

13. Replace the adjustment pot weather seal plug and your calibration is complete.

**NOTE:** A.) To change light bulb, twist black socket assembly one-eighth turn counterclockwise until it pops out. Bulb pulls straight out of assembly. It is a GE No. 194 instrument lamp.

B.) If your Tachometer is equipped with an hourmeter, the hourmeter will be energized when the engine is running.