

## Two-cylinder smoothness in a compact 18 horsepower...

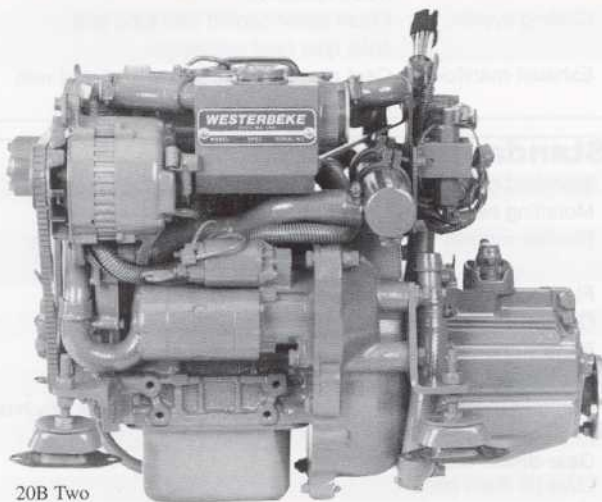

20B Two  
Diesel Engine

### Lightweight and Compact

The 20B Two has one of the smallest available envelopes in the Westerbeke line. This lightweight, low profile engine is designed to fit into the smallest of engine compartments.

### Powerful and Reliable

The 20B Two is a powerful, two-cylinder engine rated at 18 horsepower. Specially engineered by Westerbeke, pioneers in marine diesel engines, the 20B Two provides consistent performance, durability and, above all, reliability year after year.

### Easy Operation and Maintenance

To minimize engine maintenance, the 20B Two is fresh water-cooled and equipped with a simple control system. Easy access to all servicing points and a self-bleeding fuel system allow easy routine maintenance. The 20B Two is easy to install, economical to operate and has a full range of options available allowing you to custom tailor your engine.

### Full Engine Instrumentation Option

Westerbeke offers an optional admiral panel. The admiral panel includes, tachometer, hour meter, volt-meter, water temperature and oil pressure gauge. Westerbeke also offers an optional captain panel with tachometer, hour meter, and warning lights.

### The Name You Can Trust

The presence of Westerbeke in over 65 countries around the world provides customers with easy access to parts, service and technical support worldwide. Established in 1937, Westerbeke is committed to providing its customers with quality products and unequalled after sales support.

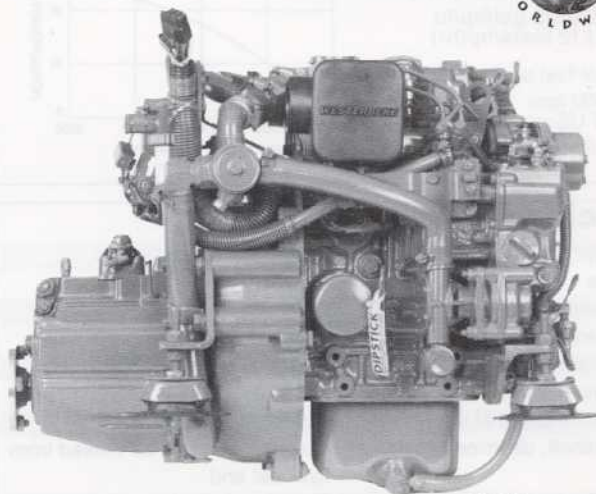

20B Two  
Diesel Engine

### Standard Features

- Fresh water cooling
- Engine pre-wired to plug-in connector
- Self-bleeding fuel system
- 12 volt, 50 amp alternator
- Flow control domestic hot water connection
- Coolant recovery tank
- Throttle, stop, and shift control brackets
- Low oil pressure and high water temperature alarms
- Gear driven raw water pump
- Mechanical gear with 2.47:1 reduction
- Glow plug cold starting aid
- Four point adjustable flex mounts
- Lube oil drain hose
- Tuned air intake silencer
- Operators' manual and parts list
- EPA certified
- "CE" Mark



*Optional Admiral Panel*

### Admiral Panel Dimensions

Length	9.75" (247.7 mm)
Depth	4.0" (101.6 mm)
Height	6.0" (152.4 mm)

### Performance Data

Horsepower and rpm  
18 hp @ 3600 rpm  
13.4 KW

Maximum torque and rpm  
30 lbs/ft @ 2200 rpm

Typical fuel consumption  
0.056 US gal/hp/hr  
(0.212 liters/hp/hr)

Typical fuel consumption  
@ 2500 rpm  
0.7 US gal/hr  
(2.65 liters/hr)

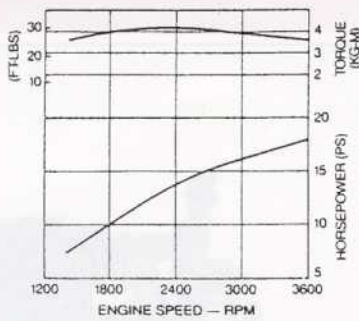

### Specification

Number of cylinders	2 Cylinder vertical in-line
Cycles	4 Cycle
Displacement	38.75 cu. in. (.63 liter)
Bore and stroke	2.99" x 2.76" (76 mm x 70 mm)
Compression ratio	23:1
Maximum angle of installation	Not to exceed 14°
Maximum angle of operation	Not to exceed 25°
Crankshaft, direction of rotation	Counterclockwise as viewed from flywheel end
Propeller shaft, direction of rotation	Right hand – std. trans.
Dry weight	225 lbs (102.1 kilos)
Combustion system	Swirl type
Aspiration	Naturally aspirated
Lubrication system	Forced lubrication by gear pump
Cooling system	2.9 quarts (2.7 liters)
Starting aid	12 volt sheathed type glow plug
Engine stop	Manual Type
Fuel injection pump	Bosch type
Governor	Centrifugal type
Injectors	Throttle type
Fuel filter	Secondary, replaceable type
Lube oil filter	Full flow, spin-on element
Lubricant capacity	0.634 US gal (2.4 liters)
Fuel transfer pump	Mechanical diaphragm type
Fuel supply and return piping	1/4" ID (6.35 mm) minimum 3/8" ID (9.65 mm) maximum
Starting motor	12 volt, solenoid, actuated shift
Battery charging alternator	50 ampere (12 volts)
Cold cranking amps	125 amps
Alternator/regulator	Automatic, solid state built-in
Electrical system	12 volts DC, negative ground

### Construction – Engine Components

Cylinder head	Cast Iron
Cylinder block	Cast Iron
Crankshaft	Forged crankshaft, three main bearings
Valves	Overhead valves, rotating type
Fuel System	Self bleeding
Intake system	Tuned intake silencer for maximum noise reduction
Cooling system	Fresh water-cooled with tube and shell type heat exchanger
Exhaust manifold	Cast aluminum, fresh water-cooled with built-in expansion tank

### Standard Equipment

Standard gear ratio	2.05:1
Mounting centers	14.56"
Flexible mounts	Adjustable fail-safe rubber type
Flow control domestic hot water connection	
Coolant recovery tank	
Battery charging alternator	
Starting aid	
Control brackets	For all control attachments
Prewired Engine	
Gear-driven sea water pump	
Lube oil drain hose	
Tuned air intake silencer	
Oil fill	Top and service side
Circuit breaker protected electrical system	
Operator's Manual	
Parts List	

### Optional Equipment

Captain panel with alarm (tachometer with lights)	
Admiral panel with alarm (tachometer with gauges)	
Dual station senders	
Other gear ratios	Consult local Distributor
Remote expansion tank	
Fuel/water separator	
Muffler and fittings	
"A" on board spare parts kits	
"B" extended cruising spare parts kits	
Anti-siphon valve for overboard cooling discharge water	
Technical Manual	
Exhaust connection (water injected 90°, 45° elbows & riser)	
Propeller shaft couplings (rigid/flexible) – available standard sizes	

### Dimensions

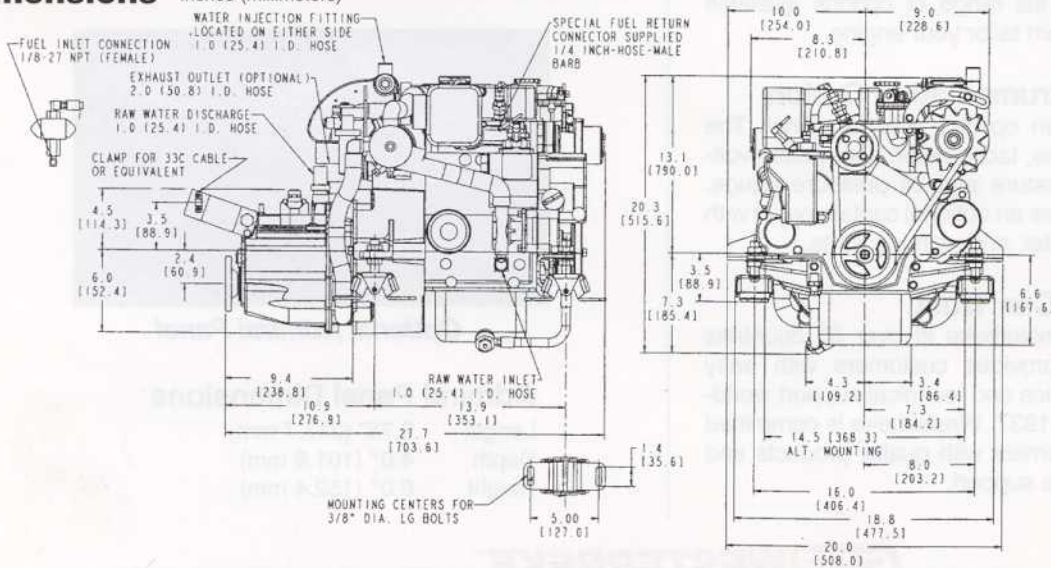

Authorized Dealer