

## Long lasting 3000-rpm performance...

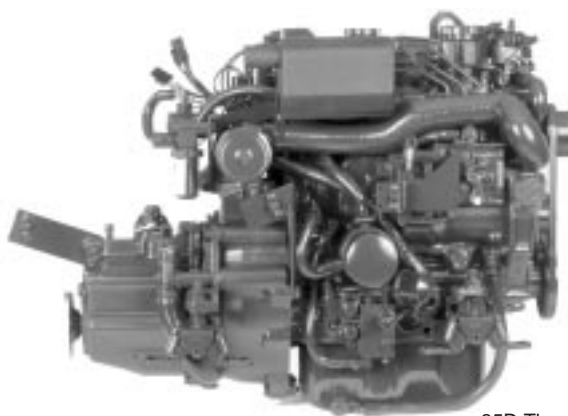

35D Three  
Diesel Engine



35D Three  
Diesel Engine

### Lightweight and Compact

Designed by Westerbeke, pioneers in lightweight marine diesel engines, the 35D Three is a compact three-cylinder engine perfect for difficult installations. The 35D Three provides a power to weight ratio to be envied while requiring modest engine room space.

### Powerful, Reliable and Quiet

The 35D Three is rated at a low 3000-rpm for longer engine life. It is designed and built using experience gained in supplying over 1,100 whaleboat engines to the United States Navy. The 80.43 cubic inch displacement of the 35D Three delivers reliable power without sacrificing smooth and quiet operation. For enhanced quiet performance, this engine also has tuned air intake silencer.

### Easy Operation and Maintenance

To minimize engine maintenance, the 35D Three is fresh water cooled and equipped with a simple control system. Easy access to all servicing points and a self-bleeding fuel system allow easy installation and routine maintenance.

### Full Engine Instrumentation Option

Westerbeke offers an optional admiral panel. The admiral panel includes, tachometer, hour meter, voltmeter, water temperature and oil pressure gauge. Westerbeke also offers an optional captain panel with tachometer, hour meter, and warning lights.

### The Name You Can Trust

The presence of Westerbeke in over 65 countries around the world provides customers with easy access to parts, service and technical support worldwide. Established in 1937, Westerbeke is committed to providing its customers with quality products and unequalled after sales support.

### Standard Features

- Fresh water cooling
- Engine pre-wired to plug-in connector
- Self-bleeding fuel system
- 12 volt 50 ampere alternator
- Flow control domestic hot water connections
- Coolant recovery tank
- Throttle, stop, and shift control brackets
- Low oil pressure and high water temperature alarms
- Gear driven raw water pump
- Short profile marine gear with 2.0:1 reduction
- Glow plug cold starting aid
- Four point adjustable flex mounts
- Lube oil drain hose
- Tuned air intake silencer with filter
- Operators' manual and parts list
- EPA certified
- "CE" mark



*Optional Admiral Panel*

### Admiral Panel Dimensions

Length	9.75" (247.7 mm)
Depth	4.0" (101.6 mm)
Height	6.0" (152.4 mm)

### Performance Data

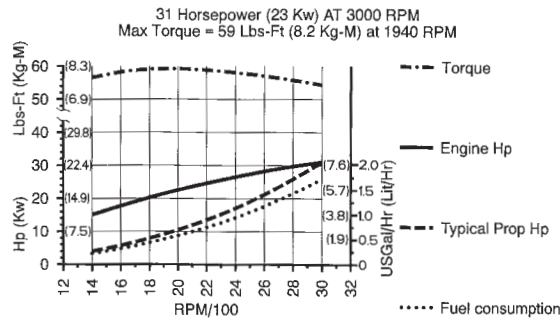

Westerbeke recommends a propeller that will allow the engine to turn 3000 RPM underway at full throttle

### Specifications

Number of cylinders	3 Cylinder vertical in-line
Cycles	4 Cycle
Displacement	80.43 cu. in. (1.318 liter)
Bore and stroke	3.07" x 3.62" (78 mm x 92 mm)
Compression ratio	22:1
Maximum angle of installation	Not to exceed 14°
Maximum angle of operation	Not to exceed 30° for 30 min.
Crankshaft, direction of rotation	Counterclockwise as viewed from flywheel end
Propeller shaft, direction of rotation	Right hand – std. trans.
Dry weight	386 lbs (175.1 kilos)
Combustion system	Swirl type
Aspiration	Naturally aspirated
Lubrication system	Forced lubrication by trochoid pump
Cooling system	5 quarts (4.73 liters)
Starting aid	12 volt sheathed type glow plug
Engine stop	Manual type
Fuel injection pump	Bosch type
Governor	Centrifugal type
Injectors	Throttle type
Fuel filter	Primary
Lube oil filter	Full flow, spin-on element
Lubricant capacity	.98 U.S. gallons (3.7 liters)
Fuel transfer pump	Electric
Fuel supply and return piping	1/4" ID (6.35 mm) minimum 3/8" ID (9.53 mm) maximum
Starting motor	12 volt, solenoid actuated
Battery charging alternator	50 ampere (12 volts)
Cold cranking amps	237 amps
Alternator/regulator	Automatic, solid state built-in
Electrical system	12 volts DC, negative ground

### Construction – Engine Components

Cylinder head	Cast Iron
Cylinder block	Cast Iron
Crankshaft	Forged crankshaft, four main bearings
Valves	Overhead valves, rotating type
Fuel System	Self bleeding
Intake system	Tuned intake silencer for maximum noise reduction
Cooling system	Fresh water-cooled with tube and shell type heat exchanger
Exhaust manifold	Cast aluminum, fresh water-cooled with built-in expansion tank

### Standard Equipment

Standard gear ratio	2.0:1
Mounting centers	14.6", 16.0" or 18.5"
Flexible mounts	Adjustable fail safe rubber type
Flow control domestic hot water connection	
Coolant recovery tank	
Battery charging alternator	50 amp
Starting aide	
Control brackets	For all control attachments
Prewired Engine	
Gear-driven raw water pump	
Lube oil drain hose	
Transmission oil cooler	
Oil fill	Top and service side
Circuit breaker protected DC electrical system	
Operator's Manual and Parts List	

### Optional Equipment

Captain panel with alarm (tachometer with lights)	
Admiral panel with alarms (tachometer with gauges)	
Dual station senders	
Other gear ratios	Consult local Distributor
72 amp alternator in place of standard	
Remote expansion tank	
Fuel/water separator	
Muffler and fittings	
"A" on board spare parts kits	
"B" extended cruising spare parts kits	
Anti-siphon valve for overboard cooling discharge water	
Technical Manual	
Exhaust connection (water injected 45° or 90° elbow)	
Propeller shaft couplings (rigid/flexible) – available standard sizes	

### Dimensions Inches (millimeters)

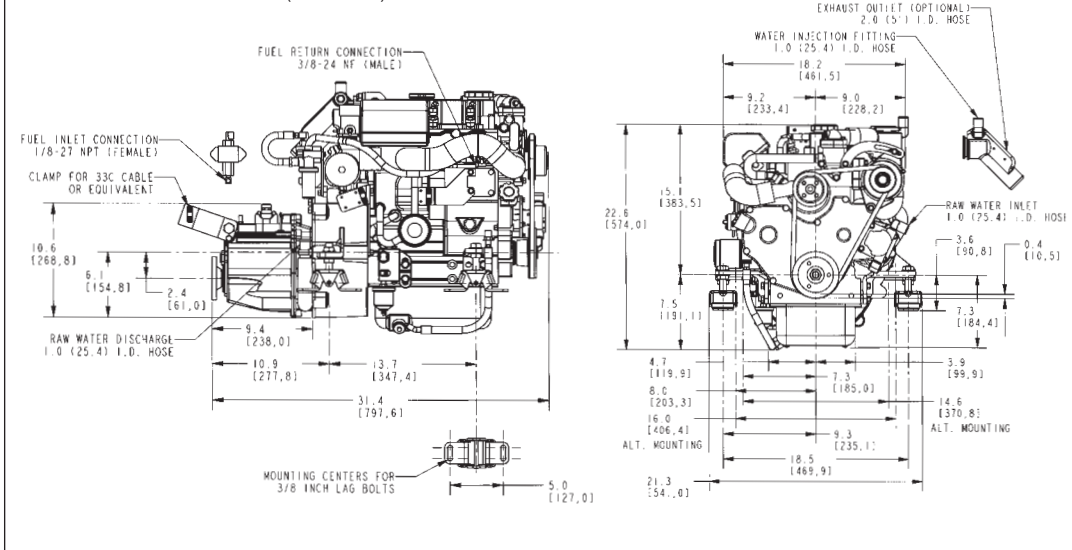

Authorized Dealer