

# WESTERBEKE

## DIESEL GENERATOR

# 12.5 BTDB<sub>60Hz</sub> 9.4 BTDB<sub>50Hz</sub>

### The truly "quiet breed" of reliable power...

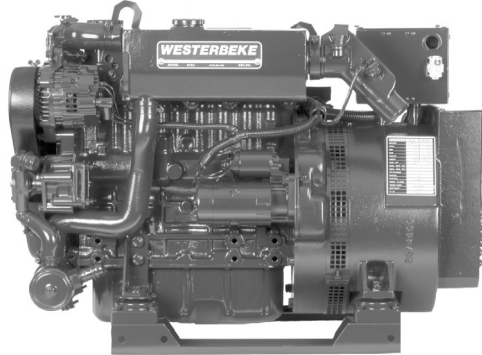

12.5BTDB Diesel Generator

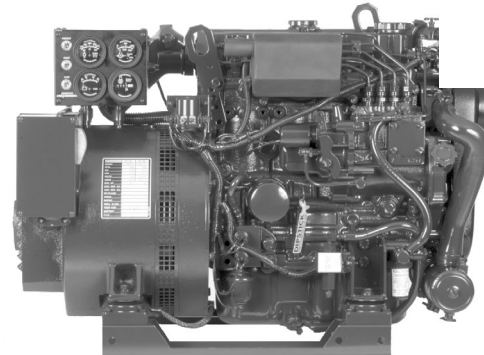

12.5BTDB Diesel Generator

#### Quiet, Compact and Lightweight

Designed by Westerbeke, the Company that pioneered the truly "quiet breed" of generators, the 4-cylinder 12.5 BTDB is a smooth, quiet and compact diesel generator. The 12.5 BTDB also provides one of the best power to weight ratios of any generator in its class.

#### Powerful and Reliable

The 12.5 BTDB is reliable because it is specially engineered to operate in a hostile marine environment. It is designed and built using experience gained in supplying generators to the United States Navy and Coast Guard. Powerful but lightweight, it is economical to operate and designed to run at a slow 1800 rpm for less noise and greater longevity.

#### Simple, Easy Operation and Maintenance

To minimize engine maintenance, the 12.5 BTDB is fresh water cooled and equipped with a simple control system rather than complex, troublesome, electronic components. Easy access to all servicing points and individually removable top and side panels of the optional sound enclosure allow easy installation and maintenance.

#### Full Torque, Power Take-Off Interface

A customer sourced, electric clutch and hydraulic pump can be mounted to the full torque, power take-off interface for use with such items as bow thrusters, compressors, winches and "take-home" systems.

#### Five Year Limited Warranty

The 12.5 BTDB is backed by Westerbeke's 5-year limited warranty. The presence of Westerbeke in over 65 countries around the world provides customers with easy access to parts, service and technical support worldwide. Established in 1937, Westerbeke is committed to providing its customers with quality products and unequalled after sales support.

#### Standard Features

- Instrument panel and safety stop switch
- Remote start-stop plug-in connection
- Extra oil pressure switch for remote signal or control functions
- Safety shut-downs - high coolant temperature, low oil pressure, high exhaust temperature
- A.C. circuit breaker (single phase)
- 50 amp alternator
- Power take-off interface
- Self-bleeding fuel system
- Fresh water cooling and coolant recovery tank
- 45 degree water injected exhaust elbow
- Gear driven raw water pump
- Vibration mounts - fail safe rubber type
- Lube oil drain hose and drip tray
- Oil fill - top and side
- Belt guard
- Operators' manual and parts list
- "CE" Mark

#### Optional Sound Guard



#### Generator Dimensions

Length	35.0" (889.0 mm)	39.8"	(1,010.9 mm)
Width	19.0" (482.6 mm)	22.8"	(579.1 mm)
Height	24.0" (609.6 mm)	25.8"	(655.3 mm)
Weight	569.0 lbs. (258.1 kilos)	627.3 lbs.	(284.5 kilos)

#### W/ S.G.

**WESTERBEKE**  
DIESEL  
GENERATOR

**12.5BTDB<sub>60Hz</sub>  
9.4BTDB<sub>50Hz</sub>**

**WESTERBEKE™**  
Engines & Generators

**12.5BTDB60Hz**  
**9.4BTDB50Hz**



**Generator Design**

**DESIGN:** Brushless, four pole, revolving field, power takeoff.  
**VOLTAGE REGULATION:** Standard +/- 5% no load to full load.  
**FREQUENCY REGULATION:** 3 Hz (5%) no load to full load.  
**INSULATION:** Class "H", as defined by NEMA MG1-1.65.

**TEMPERATURE RISE:** Within NEMA MG1-22.40 definition when operating at full load.  
**COOLING:** Cast centrifugal blower, direct connected.  
**ELECTROMAGNETIC INTERFERENCE LEVEL:** Exceeds requirements for most marine radio-telephones and standard TVs.

Model	Electrical Characteristics					Ratings		Engine	
	Volts	Amps	Hertz	Phase	Wire	Power Factor	KW	RPM	Start
12.5 BTDB-614	120/240	104/52.0	60	1	4	1.0	12.5	1800	Remote
9.4 BTDB-514	230	40.9	50	1	4	1.0	9.4	1500	Remote

Three phase units, 50 & 60 Hz, are available in these ratings.

Generator field adjustable to 50 or 60 Hz.

**Specifications**

Number of cylinders	4 Cylinder vertical in-line
Type	4 cycle
Displacement	107.27 cu. in. (1.758 liter)
Bore and stroke	3.07" x 3.62" (78 mm x 92 mm)
Compression ratio	22:1
Rated rpm	60 Hz - 1800 rpm 50 Hz - 1500 rpm
HP @ 1800/1500 rpm	25/22
Maximum angle of operation	15° continuous, 30° Intermittent
Exhaust elbow connection	2.0" OD (50.8mm)
Raw water connection	1.0" OD (25.4mm)
Dry weight	561 lbs. (254.5 kilos)
Combustion system	Swirl type
Aspiration	Naturally aspirated
Lubrication system	Forced lubrication by gear pump
Cooling system	8 quarts (7.6 liters)
Starting aid	12 volt sheathed type glow plug
Full load fuel consumption	1.19 GPH (4.50 LPH) @ 1800 rpm 0.91 GPH (3.44 LPH) @ 1500 rpm
Fuel injection pump	Bosch type
Governor	Centrifugal type
Injectors	Throttle type
Fuel Filter	Primary
Lube oil filter	Full flow, spin-on element
Fuel supply and return piping	1/4" ID (6.35 mm) minimum 3/8" ID (9.52 mm) maximum
Fuel Transfer Pump	12 Volt DC electric type

Lubricant Capacity	5.5 quarts (5.2 liters)
Starting motor	12 volt, solenoid actuated
Battery charging alternator	50 ampere (12 Volts)
Cold cranking amps	270 amps @ 69 degrees F
Alternator/regulator Electrical system	Automatic, solid state built-in 12 volts DC, negative ground

**Construction - Engine Components**

Cylinder head	Cast Iron
Cylinder block	Cast Iron
Crankshaft	Forged crankshaft, five main bearings
Valves	Overhead, rotating type
Fuel System	Self-bleeding
Intake system	Tuned intake silencer for maximum noise reduction
Cooling system	Fresh water-cooled with shell and tube type heat exchanger
Exhaust manifold	Cast aluminum, fresh water-cooled

**Optional Equipment**

- Remote start-stop panel
- 15' & 30' connectable panel ext. harness (up to 60'/18.3m)
- Dual station engine instrument panel with senders
- Electronic voltage regulator; electronic governor
- Ship-shore switch
- Power takeoff adapter
- Fuel/water separator
- Hydro-hush muffler and fittings
- "A" on board spare parts kits; "B" extended cruising spare parts kit
- Anti-siphon valve for overboard cooling discharge water
- Technical manual
- Sound Guard sound enclosure

**Dimensions** Inches (millimeters)

