



A truly low profile 7.6 kilowatts...



7.6 BTD Diesel Generator



7.6 BTD Diesel Generator

Quiet and Compact

Operating at 1800-rpm with a tuned air intake silencer and four point vibration mounts, the 7.6 BTD runs smooth and quiet. Designed specifically for those installations where height is extremely limited, this generator also has one of the smallest envelopes available in its class. The 7.6 BTD is only 20.7 inches high and occupies only 6.4 cubic feet of space!

Powerful, Lightweight and Reliable

The 7.6 BTD is powered by an industrial .95 liter engine supplying a full 7.6 kilowatts while weighing only 395 pounds. A very popular generator, the 7.6 BTD continues to support the strong record of reliability Westerbeke has built supplying generators to the United States Navy and Coast Guard as well as commercial vessels and pleasure craft.

Easy Operation and Maintenance

To minimize engine maintenance, the 7.6 BTD operates at a slow 1800-rpm and is fresh water cooled for longer life. Easy access to all servicing points and individually removable top and side panels of the optional sound enclosure allow easy installation and maintenance.

Full Torque, Power Take-Off Interface

A customer sourced, electric clutch and hydraulic pump can be mounted to the full torque, power take-off interface for use with such items as bow thrusters, compressors, winches and "take-home" systems.

Five Year Limited Warranty

The 7.6 BTD is backed by Westerbeke's 5-year limited warranty. The presence of Westerbeke in over 65 countries around the world provides customers with easy access to parts, service and technical support worldwide. Established in 1937, Westerbeke is committed to providing its customers with quality products and unequalled after sales support.

Standard Features

- Remote instrument panel with 15' extension
- Unit mounted start-stop
- Extra oil pressure switch for remote signal or control functions
- Safety shut-downs - high coolant temperature, low oil pressure, high exhaust temperature
- A.C. circuit breaker (single phase)
- 50 amp alternator
- Power take-off interface
- Self-bleeding fuel system
- Fresh water cooling and coolant recovery tank
- 45 degree water injected exhaust elbow
- Gear driven raw water pump
- Tuned air intake silencer
- Vibration mounts - fail safe rubber type
- Lube oil drain hose and drip tray
- Oil fill - top and side
- Belt guard
- Operators' manual and parts list
- EPA certified
- "CE" mark

Optional Sound Guard SST



Generator Dimensions

Length	28.2"	(716 mm)
Width	19.0"	(483 mm)
Height	20.7"	(526 mm)
Weight	395 lbs.	(179 kilos)

with Sound Guard SST

Length	33.3"	(846 mm)
Width	21.1"	(536 mm)
Height	22.3"	(566 mm)
Weight	466 lbs.	(212 kilos)

Generator Design

DESIGN: Brushless, four pole, revolving, power takeoff.
VOLTAGE REGULATION: Standard +/- 5% no load to full load.
FREQUENCY REGULATION: 3 Hz (5%) no load to full load.
INSULATION: Class "H", as defined by NEMA MG1-1.65.

TEMPERATURE RISE: Within NEMA MG1-22.40 definition when operating at full load.
COOLING: Cast centrifugal blower, direct connected.
ELECTROMAGNETIC INTERFERENCE LEVEL: Exceeds requirements for most marine radio-telephones and standard TVs.

Model	Electrical Characteristics				Ratings			Engine	
	Volts	Amps	Hertz	Phase	Wire	Power Factor	KW	RPM	Start
7.6 BTD-614*	120/240	63.3/31.6	60	1	4	1.0	7.6	1800	Remote
5.7 BTD-514*	230	24.7	50	1	4	1.0	5.7	1500	Remote

* Adjustable to 50 or 60 Hertz.

Consult factory for 120/240 volt application.

Specifications

Number of cylinders	3 Cylinder vertical in-line
Type	4 cycle
Displacement	58.09 cu. in. (.952 liter)
Bore and stroke	2.99" x 2.76" (75.9 mm x 70.0 mm)
Compression ratio	23:1
Rated rpm	60 Hz - 1800 rpm 50 Hz - 1500 rpm
HP @ 1800 rpm	11 hp
Maximum angle of operation	Not to exceed 25° in all directions
Exhaust elbow connection	2" OD (50.8mm)
Sea water connection	1" OD (25.4mm)
Dry weight	395 lbs. (179 kilos)
Combustion system	Swirl type
Aspiration	Naturally aspirated
Lubrication system	Forced lubrication by gear pump
Cooling system	4 quarts (3.78 liters)
Starting aid	12 volt sheathed type glow plug
Full load fuel consumption	0.53 GPH (2 LPH) (approx.)
Fuel injection pump	Bosch type, with solenoid shutoff
Governor	Centrifugal type
Injectors	Throttle type
Fuel Filter	Secondary, replaceable type
Fuel transfer pump	12 volt electric type
Fuel supply and return piping	1/4" ID (6.35 mm) minimum 3/8" ID (9.53 mm) maximum
Lube oil filter	Full flow, spin-on element

Lubricant capacity	3.8 quarts (3.6 liters)
Starting motor	12 volt, solenoid, actuated shift
Alternator	50 amps
Cold cranking amps	190 amps
Electrical system	12 volts DC, negative ground

Construction - Engine Components

Cylinder head	Cast Iron
Cylinder block	Cast Iron
Crankshaft	Forged crankshaft, four main bearings
Valves	Overhead valves, rotating type
Fuel System	Self bleeding
Intake system	Tuned intake silencer for maximum noise reduction
Cooling system	Fresh water-cooled with heat exchanger
Exhaust manifold	Cast aluminum, fresh water-cooled

Optional Equipment

- Remote start-stop panel
- 15' & 30' connectable panel ext. harness (up to 60'/18.3m)
- Dual station engine instrument panel with senders
- Ship-shore switch
- Power takeoff adapter
- Fuel/water Separator
- Hydro-hush muffler and fittings
- "A" on board spare parts kits; "B" extended cruising spare parts kit
- Anti-siphon valve for overboard cooling discharge water
- Technical manual
- Sound Guard sound enclosure

Dimensions

Inches
(millimeters)

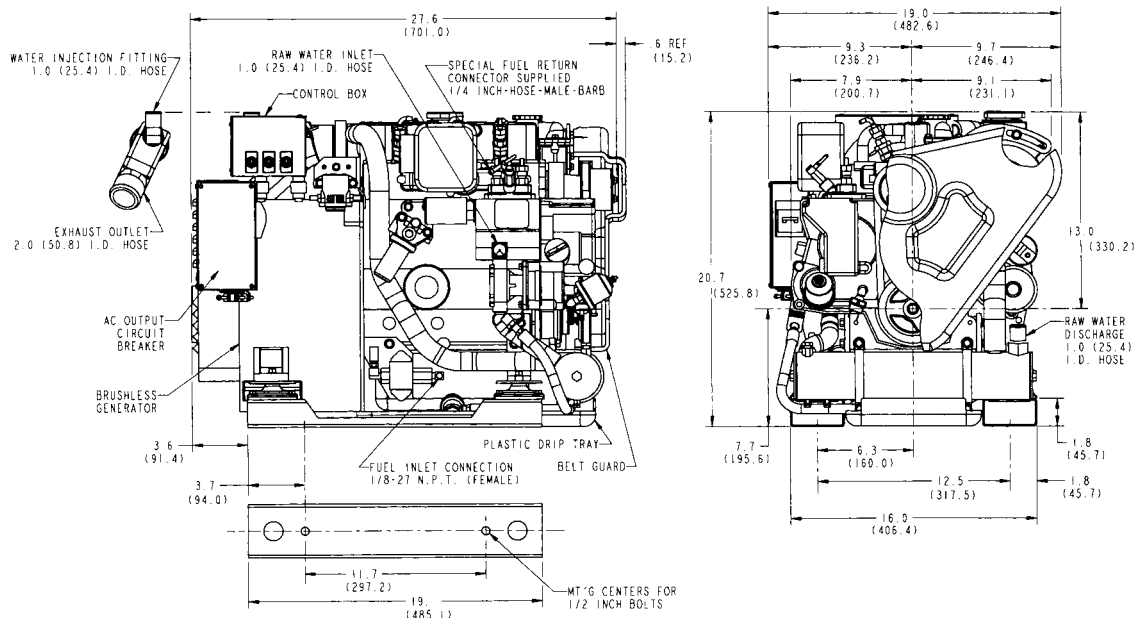

Distributor/Dealer